

Status of the Levitated Dipole Experiment

D.T. Garnier, A.K. Hansen, M.E. Mael, E.E. Ortiz

Columbia University

A. Boxer, J. Ellsworth, I. Karim, J. Kesner, I. Karim, S.
Mahar, J. Minervini, P. Michael, A. Roach,
A. Zhukovsky

MIT Plasma Science and Fusion Center

Presented at the

Innovative Confinement Concepts Workshop 2004

Madison, Wisconsin

May 25, 2004

Columbia University



Abstract

- The Levitated Dipole Experiment (LDX) is the first experiment to investigate the behavior of high-temperature plasma confined by a levitated magnetic dipole. LDX will test recent theories showing unique equilibrium and stability properties of confined plasma with stationary profiles. The LDX physics plan includes the study of high- β plasma, investigation of dipole confinement characteristics, the formation of convective cells within the closed field line geometry, and the possibility of non-local transport.
- LDX consists of a large, high-field, superconducting coil magnetically levitated within a large vacuum vessel. Since field lines pass through the inner bore of the floating coil, the plasma is not lost to the poles. High-temperature plasma having pressure comparable to the confining magnetic pressure $\beta \sim 1$ can be produced and studied.
- With its three super-conducting magnets, LDX highlights the role of innovative magnetic technology that makes possible explorations of entirely new confinement concepts. Construction of all magnet systems is now complete.
 - The advanced floating coil cryostat, which limits the heat load from the plasma to the ~ 5 °K cold mass, has undergone its final close out welds and acceptance cold test.
 - The 8-ton, 4 MA charging coil, arrived in September, 2003 at MIT from its manufacturer, the SINTEZ Efremov Institute in St. Petersburg, Russia. The coil has been installed and tested in its operating position under the LDX vacuum chamber.
 - Finally, fusion's first high-temperature superconducting magnet, the LDX levitation coil, is complete, fully tested and installed at MIT.
- We describe the project goals, overall program plan, and current status of the experiment.

Why is dipole confinement interesting?

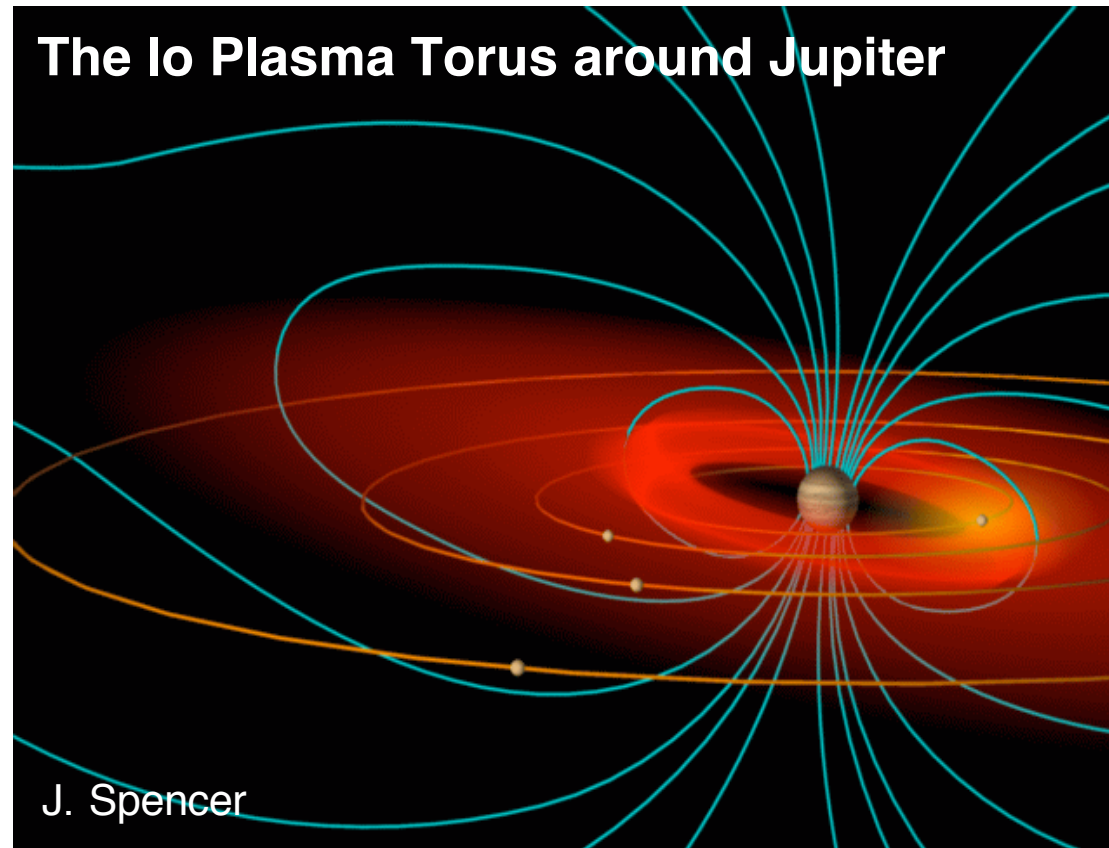

- Simplest confinement field
- High- β confinement occurs naturally in magnetospheres ($\beta \sim 2$ in Jupiter)
- Possibility of fusion power source with near-classical energy confinement
- Opportunity to study new physics relevant to fusion and space science

Dipole Plasma Confinement

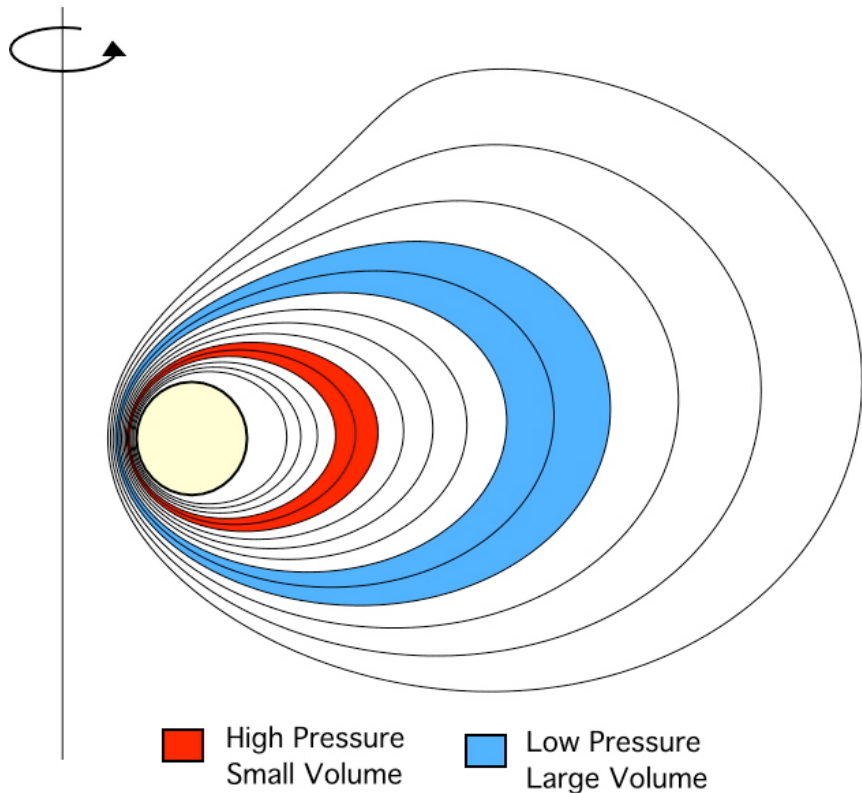

If $p_1 V_1^\gamma = p_2 V_2^\gamma$, then interchange does not change pressure profile.

For $\eta = \frac{d \ln T}{d \ln n} = \frac{2}{3}$, density and temperature profiles are also stationary.

- Toroidal confinement without toroidal field
 - Stabilized by plasma compressibility
 - ◆ Not average well
 - ◆ No magnetic shear
 - No neoclassical effects
 - No TF or interlocking coils
- Poloidal field provided by internal coil
 - Steady-state w/o current drive
 - $J_{\parallel} = 0$ -> no kink instability drive

Dipole Confinement continued...

- Marginally stable profiles satisfy adiabaticity condition.

➤ M.N. Rosenbluth and Longmire, *Ann. Phys.* 1 (1957) 120.

$$\delta(pV^\gamma) = 0, \text{ where } V = \oint \frac{dl}{B}, \gamma = \frac{5}{3}$$

- Equilibria exist at high- β that are interchange and ideal MHD ballooning stable
- For marginal profiles with $\eta = 2/3$, dipoles also drift wave stable
 - Near-classical confinement ?
 - Drift waves exist at other values of η , but with reduced growth rates
- No Magnetic Shear -> Convective cells are possible
 - For marginal profiles, convective cells convect particles but not energy.
 - ◆ Possible to have low τ_p with high τ_E .
 - Convective cells are non-linear solution to plasmas linearly unstable to interchange

LDX Experiment Cross-Section

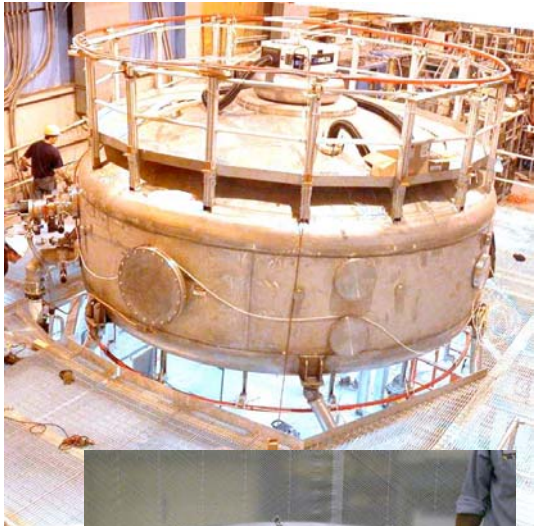
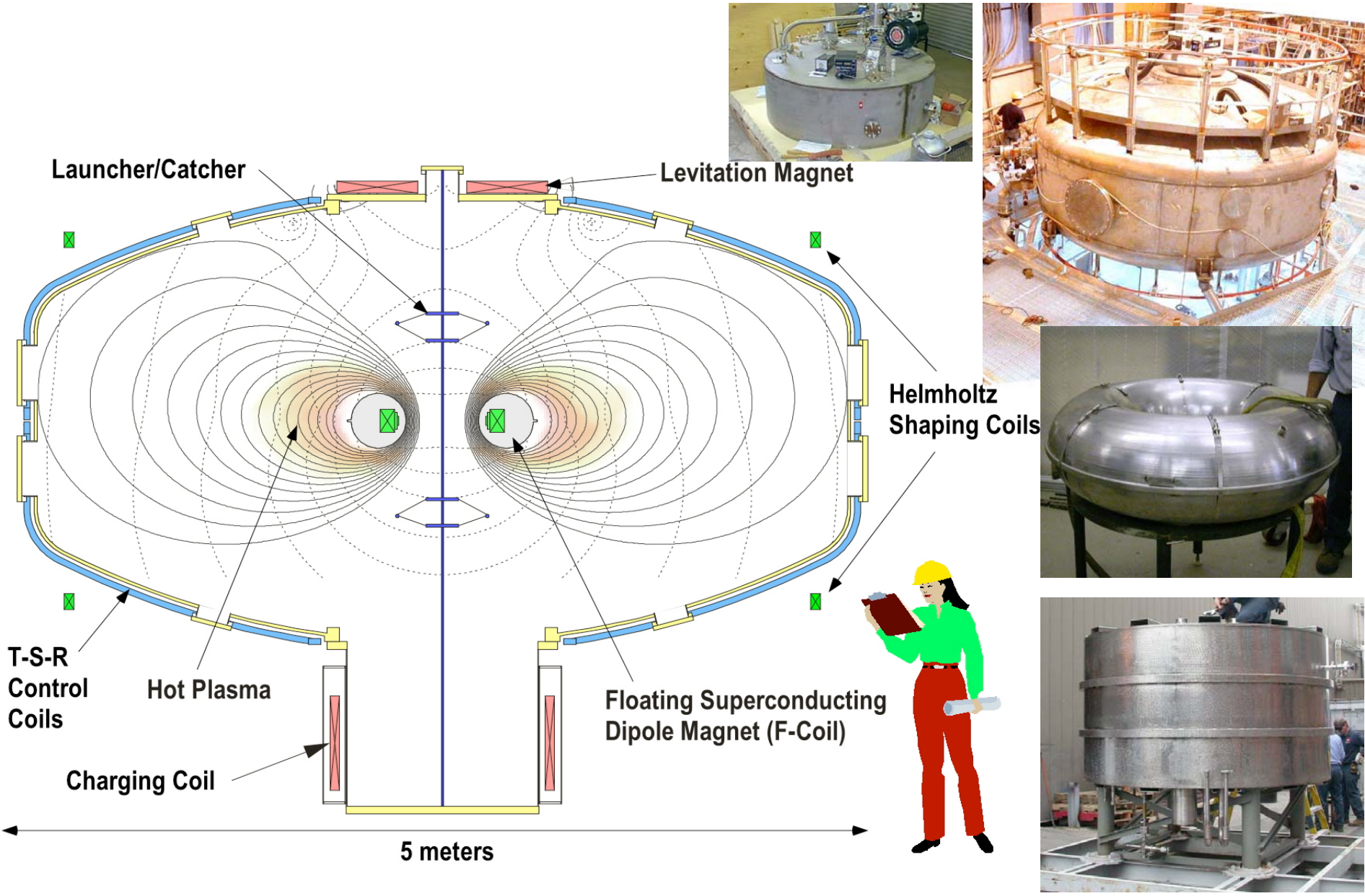

LDX Test Cell

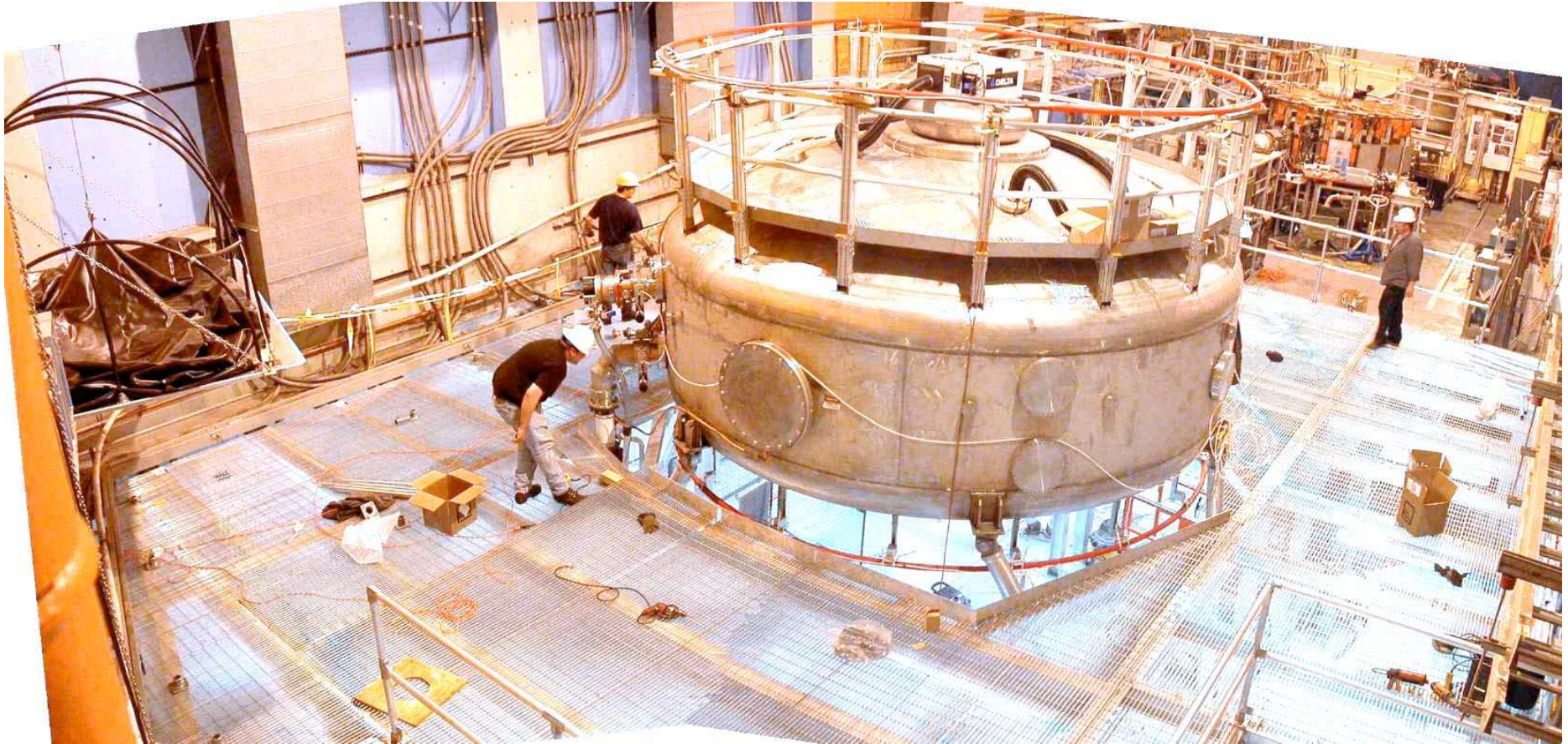

- MIT provided support stand installed May 2003
 - Doubles available space surrounding LDX
 - Provides safe and easy access to LDX diagnostic ports
 - Provision made for possible future lead shielding wall

LDX Vacuum Vessel

- Specifications
 - 5 meter (198") diameter, 3 m high, elevated off chamber floor
 - 11.5 Ton weight
 - Manufactured by DynaVac, Inc. (1999)
- Glow Discharge Cleaning
 - Tested March 2004

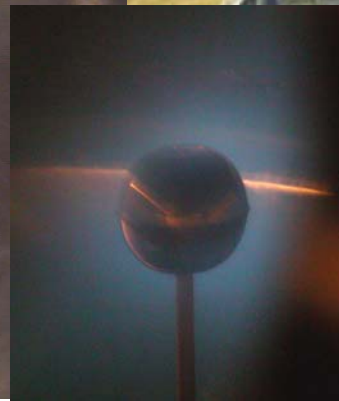

LDX Floating Coil

- Unique high-performance Nb₃Sn superconducting coil
 - 1.5 MA, 800 kJ (maximum)
 - 1300 lbs weight
 - Inductively charged
- Cryostat made from three concentric tori
 - Helium Pressure Vessel
 - Lead Radiation Shield
 - Outer Vacuum Shell
- Current Status
 - Construction complete
 - ◆ Cold test 5/04
 - ◆ Installed in LDX Chamber

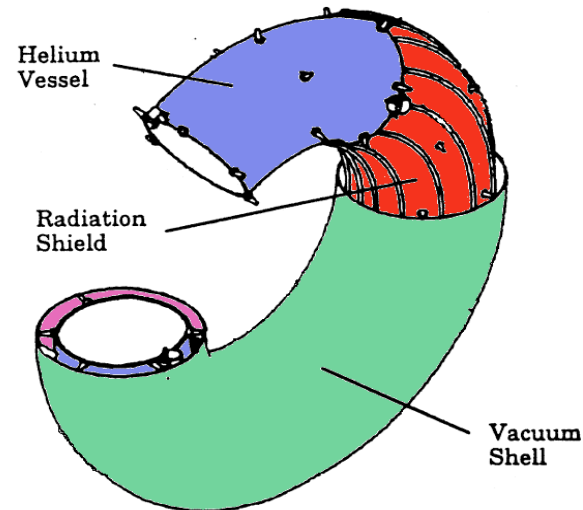

Floating Coil Cross-Section

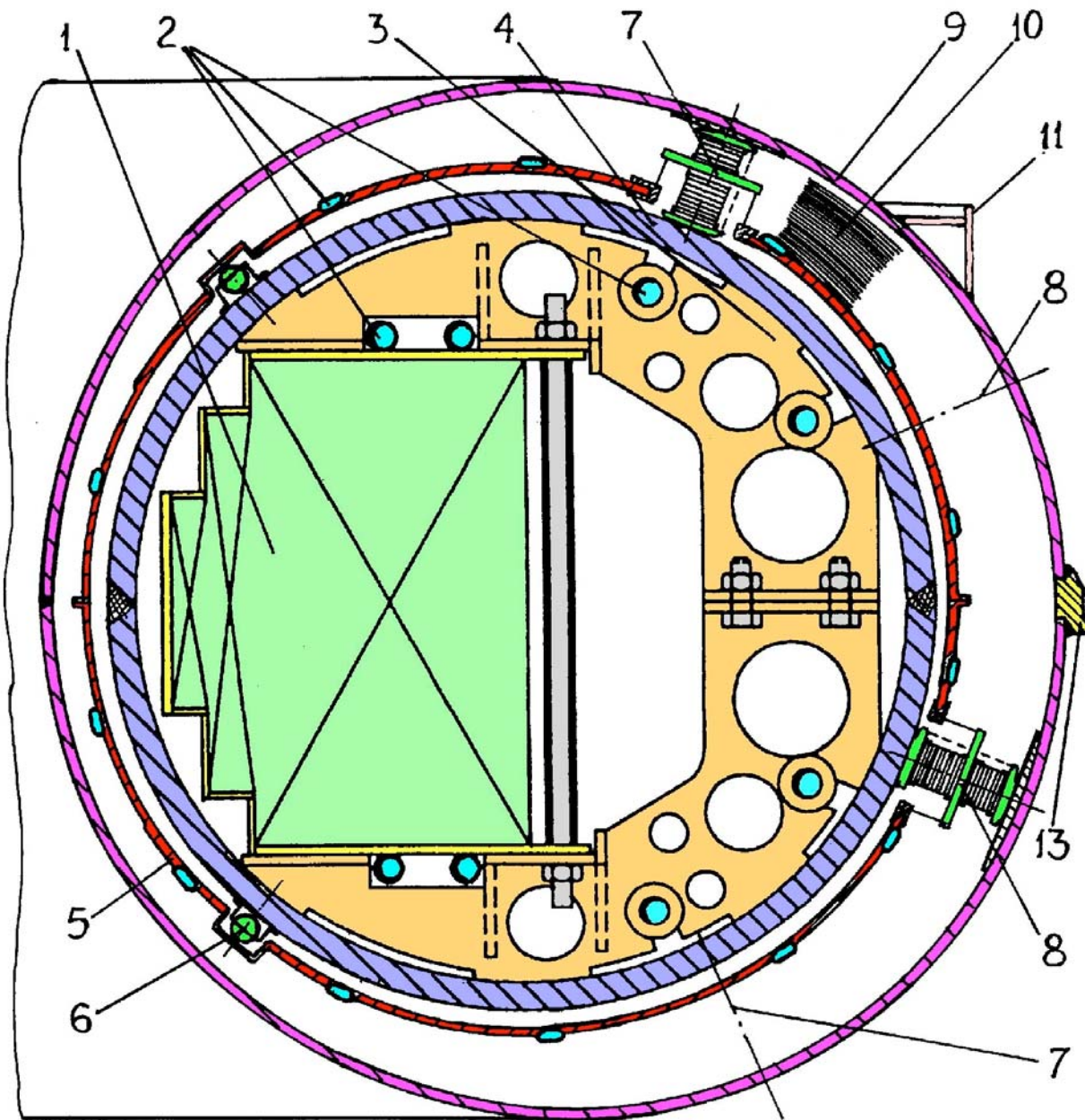

1. Magnet Winding Pack
2. Heat Exchanger tubing
3. Winding pack centering clamp
4. He Pressure Vessel (Inconel 625)
5. Thermal Shield (Lead/glass composite)
6. Shield supports (Pyrex)
7. He Vessel Vertical Supports/Bumpers
8. He Vessel Horizontal Bumpers
9. Vacuum Vessel (SST)
10. Multi-Layer Insulation
11. Laser measurement surfaces
13. Outer structural ring

Floating Coil Winding Pack

Advanced Nb₃Sn react & wind conductor...

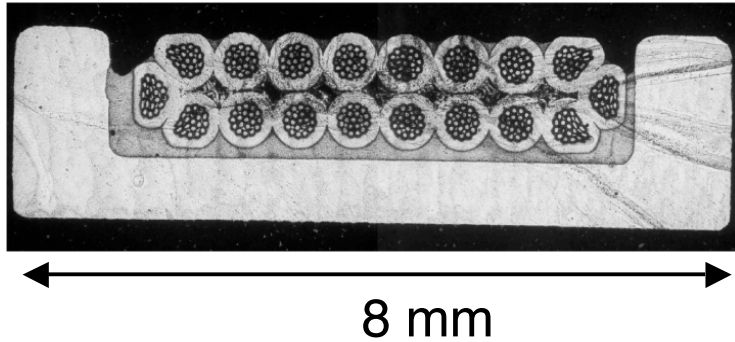

... wound very carefully...

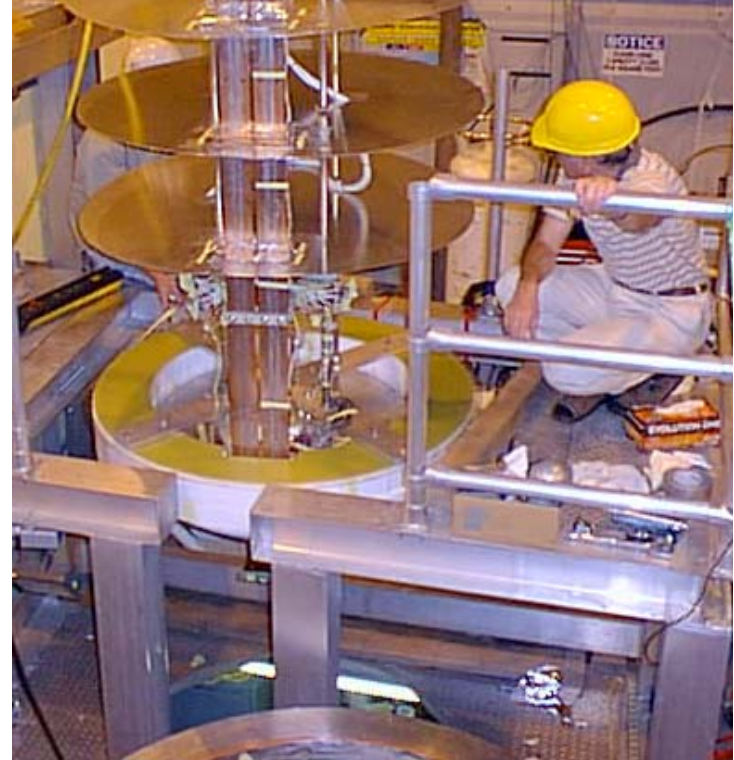

... epoxied and finally tested to full current (1.56 MA) and field (6 T) in 4.2K LHe bath.

F-Coil Helium Pressure Vessel

- Inconel 625 Pressure Vessel
 - 125 ATM at 300°K
 - 2-3 ATM cold
 - 1.5 kg He storage
 - Fully machined weight – 150 kg
- Completed construction at Ability Engineering Technology, South Holland, IL.
 - Pressure tested & code stamped
 - Leak test to vacuum @ 125 atm. for both vessel and heat exchanger
 - Covered in Al tape to give low emissivity at 4 K.



Thermal Radiation Shield

- “Cored” fiberglass composite construction
 - 2 fiberglass skins, 0.5mm thick and separated by core
 - Lead core panels provide thermal inertia at 20 K and intercept heat from vacuum vessel to 4 K helium vessel
 - Copper heat exchange tubing & conduction strips for cooldown
- Status
 - Fabrications and installation complete

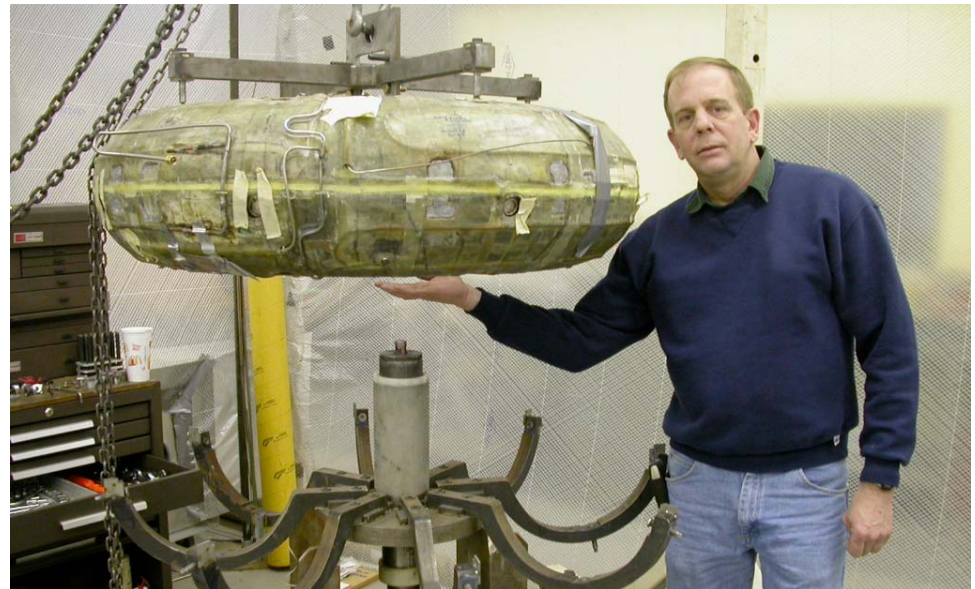

Support Washer Stacks

- Specification
 - Hold heat leak to $5\text{ K} < 10\text{ mW}$
 - Withstand 10g crash (5 Tons!)
- Solution
 - Stack of 400 4mil thick washers
- Status: Complete!
 - Prototype testing complete
 - 24 Stacks (~7000 coins)
Assembled, Sized and Installed

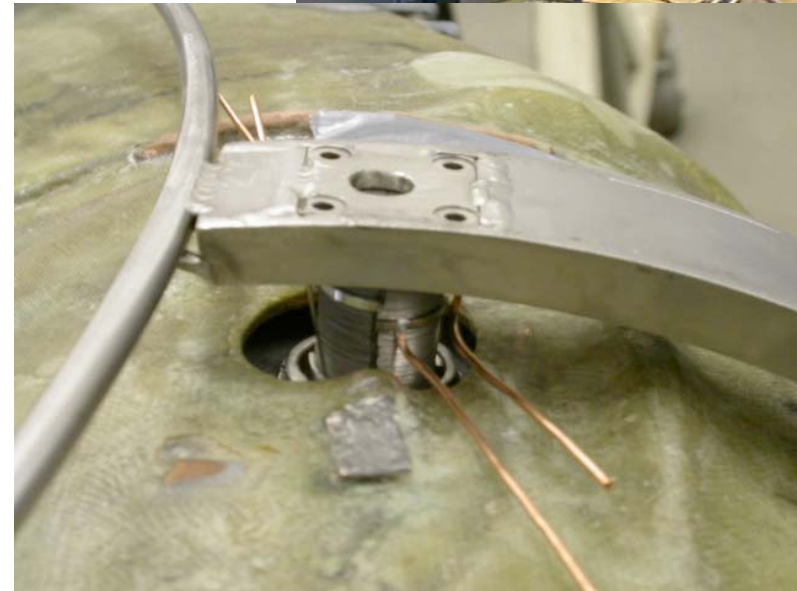
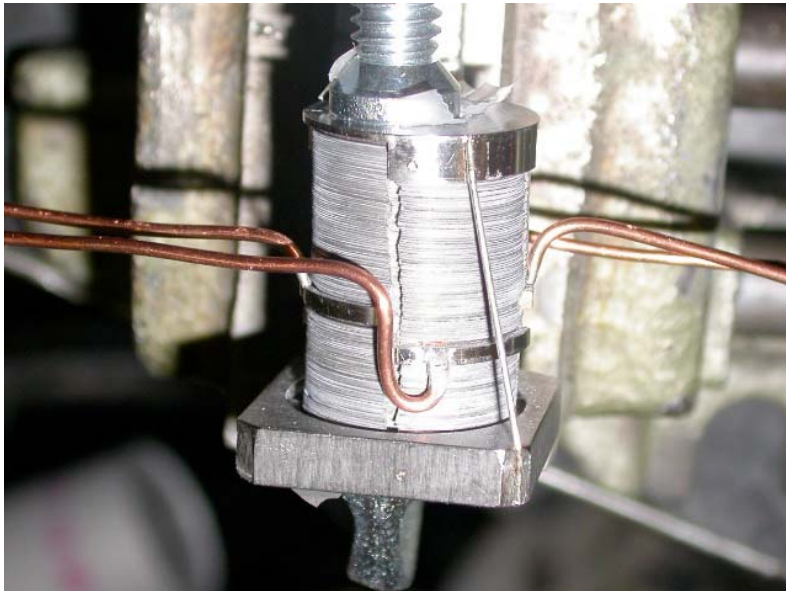
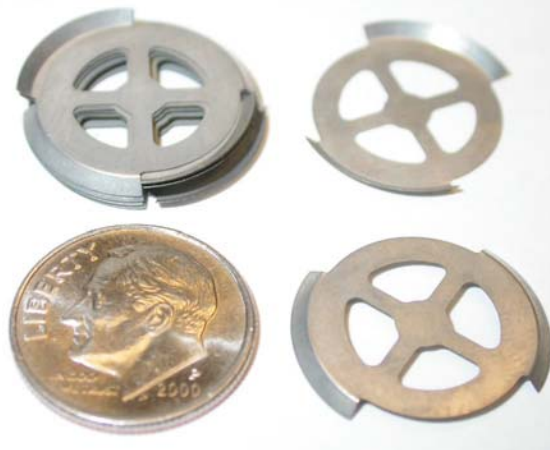

Outer Floating Coil Cryostat

- Low heat leak anti-rotation devices
- Unique low heat-leak inverted LHe feedthroughs
- Doored vacuum make/break electrical feedthrough
- Unique space frame design with stacked washer supports
- Final welds completed April, 2004.



Inverted
Cryogenic
Feedthrough



Cryostat vacuum vessel and support space frame

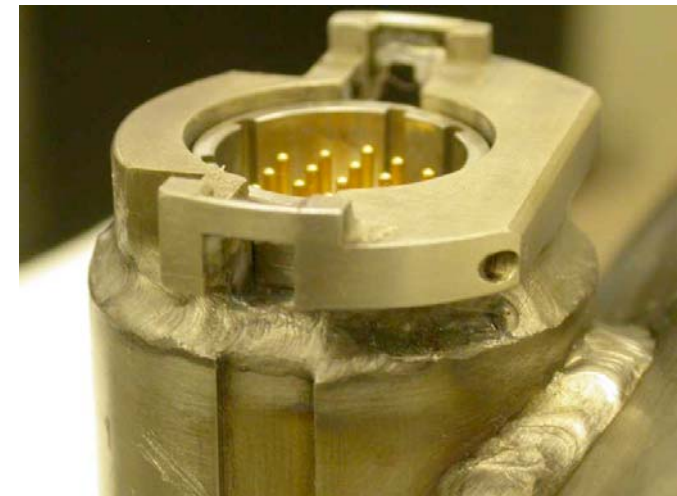

Electrical feedthrough

Floating Coil Cryogenic Test

- Liquid He cold test performed
 - April 30-May 6, 2004
- 3 Day cooling from RT to LN2 temp
- Cooling from LN2 to LHe in 7 hours
 - Result is better than expected indicating very efficient heat exchanger
- Inner He Vessel reached 4.5 °K
 - Indicates good performance of inlet transfer lines and bayonet connections
- Inner He vessel remained below 10°K for > 1 hour
 - Meets minimum requirements for operation
- Initial analyses indicate supports are at fault for extra heat leak
 - Possibly due to over-compression by close out welds

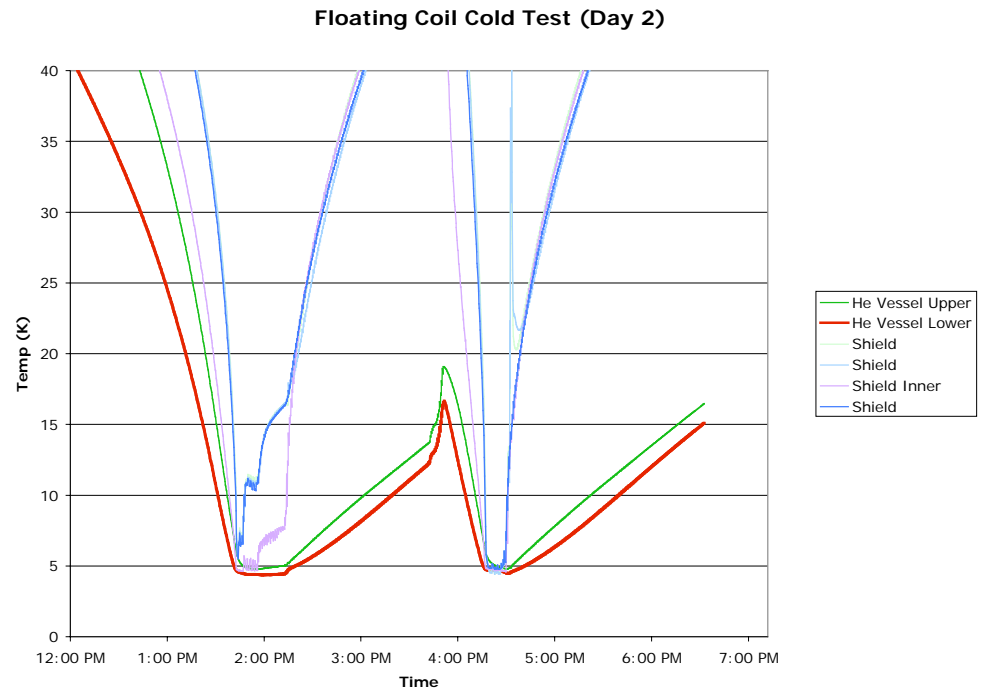

Floating Coil Installation (5/04)



Floating Coil Charging Station

- Rotary bearing table
 - Fixes radial motion but allows azimuthal alignment of feedthroughs
- Vacuum jacketed cryogenic feedthroughs
- Electrical connection for magnet temperature measurement
- Completed and Installed

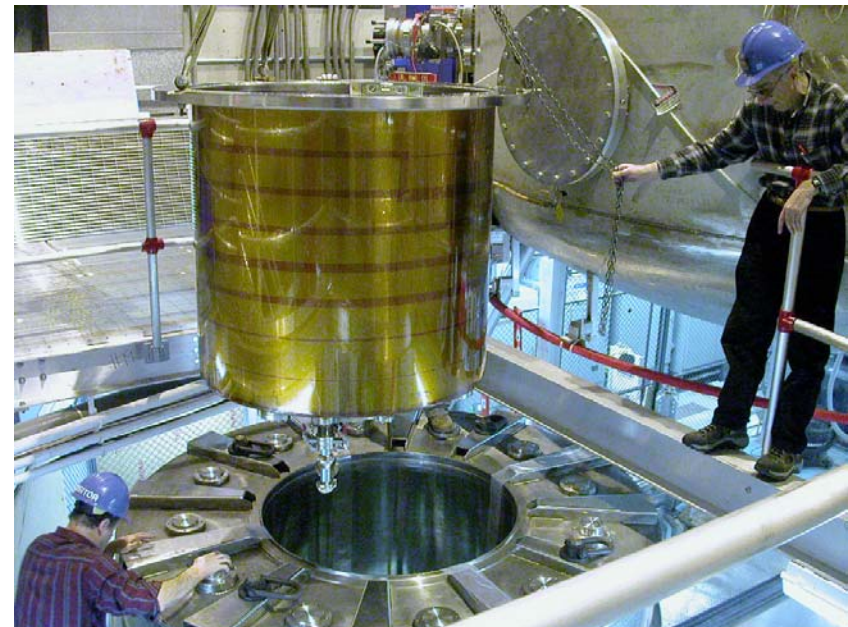
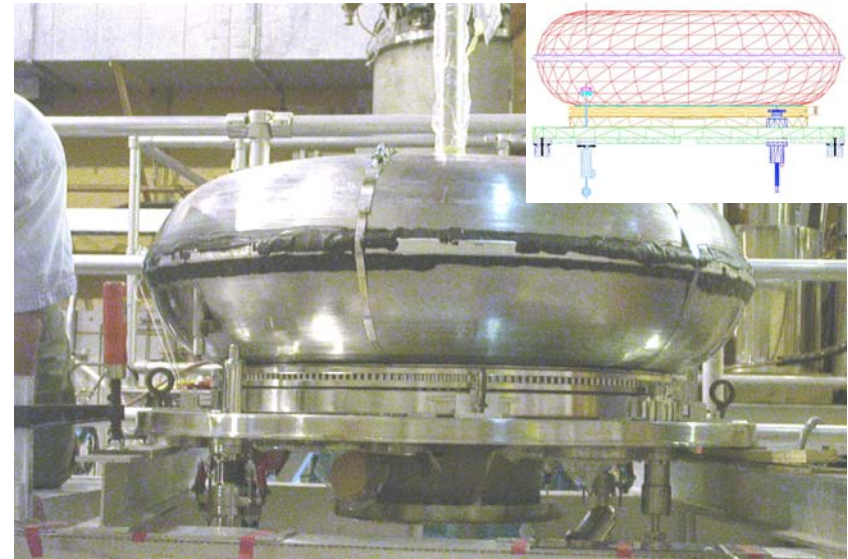
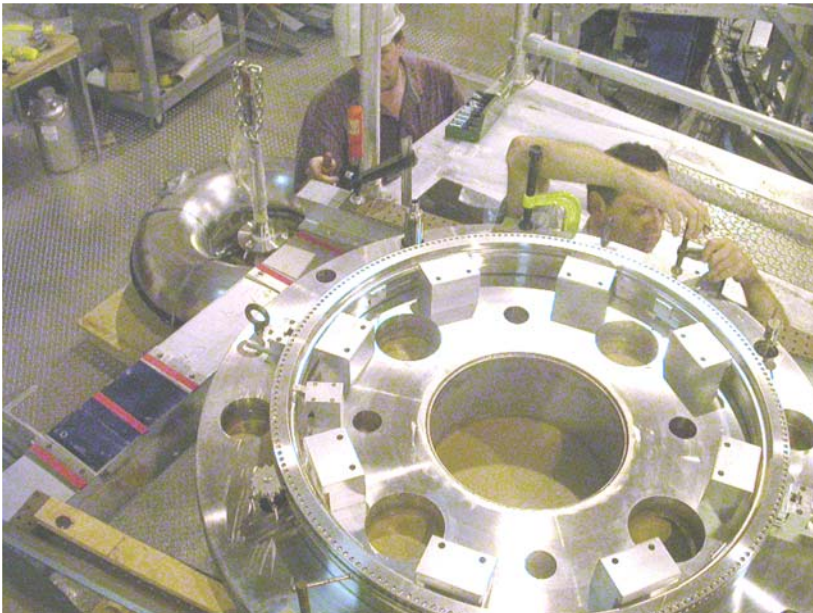

Superconducting Charging Coil

- Large superconducting coil
 - NbTi conductor
 - ◆ 4.5°K LHe pool-boiling cryostat with LN2 radiation shield
 - 1.2 m diameter warm bore
 - 4.3 T peak field (tested)
 - Cycled 2X per day
 - Ramping time for F-Coil < 30 min.

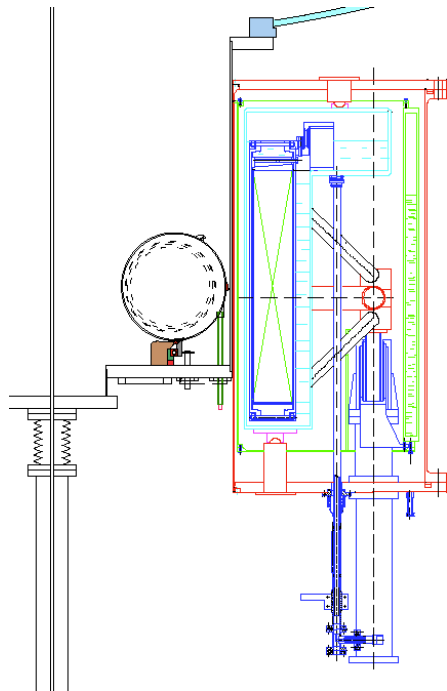

- Built and tested at SINTEZ Efremov Institute in St. Petersburg, Russia
 - Received at MIT 9/03.

Installation and Test of C-coil Complete



- Rolled under vessel and jacked up
- New support legs installed.
- Cryogenic, electrical, and control systems installed
- Systems completed and magnet tested to 400 Amps

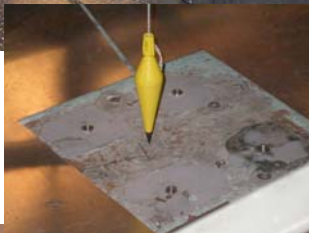

X marks the spot.

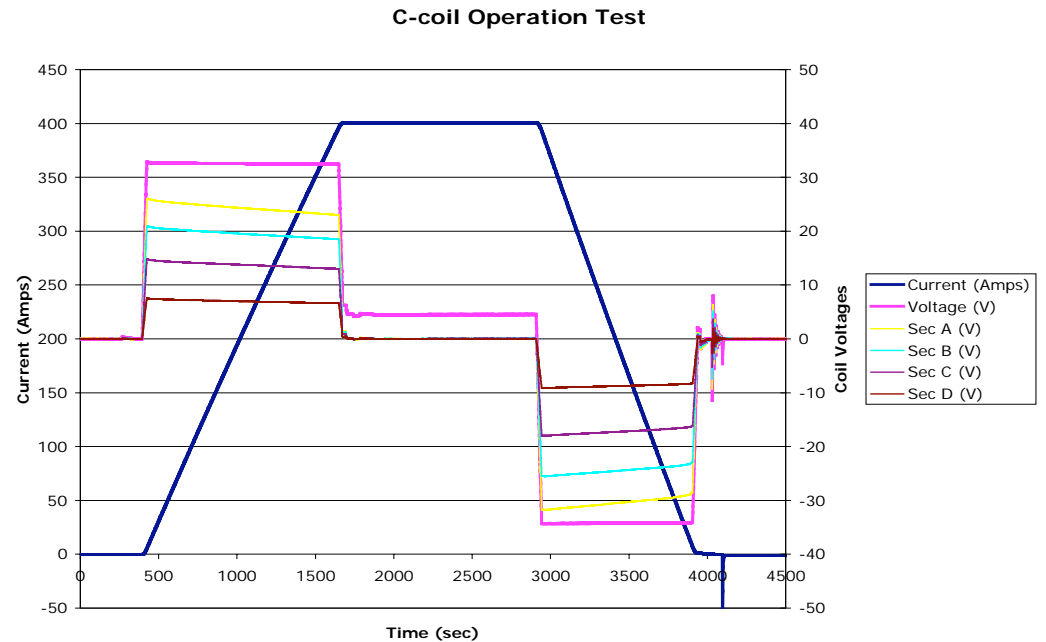

High T_c Superconducting Levitation Coil

- SBIR collaboration with American Superconductor
 - First HTS coil in the fusion community
 - Uses available BSSCO-2223 conductor
- Operational temp 20-25° K
- Feedback gain selected for 5 Hz mode frequency
 - < 20 W AC loss
- 20 kJ stored energy
 - Emergency dump in < 1 second.
- Coil Completed & Tested
 - 77° K superconducting tests successful
 - 20° K tests complete
 - Preliminary assessment: GOOD!

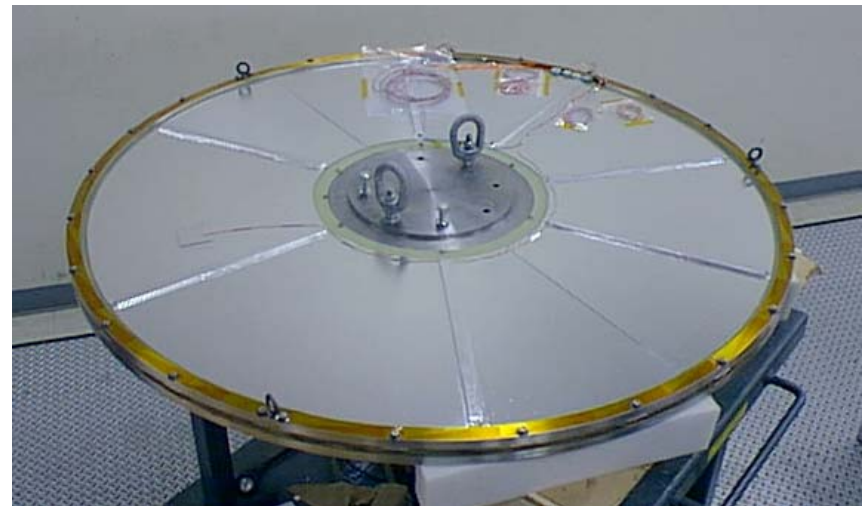
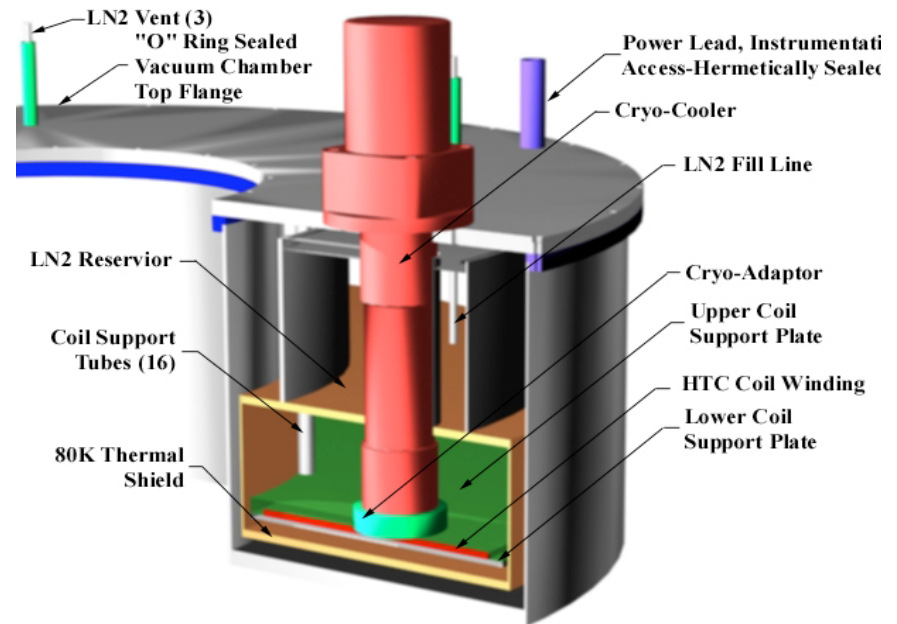

Launcher/Catcher

- Bellows feedthrough
 - High vacuum required
 - Long (> 2m) motion
- Used in both supported and levitated operation
 - Central rod limits fault motion of floating coil without interrupting plasma.
 - Integral shock absorbers to keep drop deceleration < 10g
- Status
 - Built and tested for Phase 1 (supported) operations

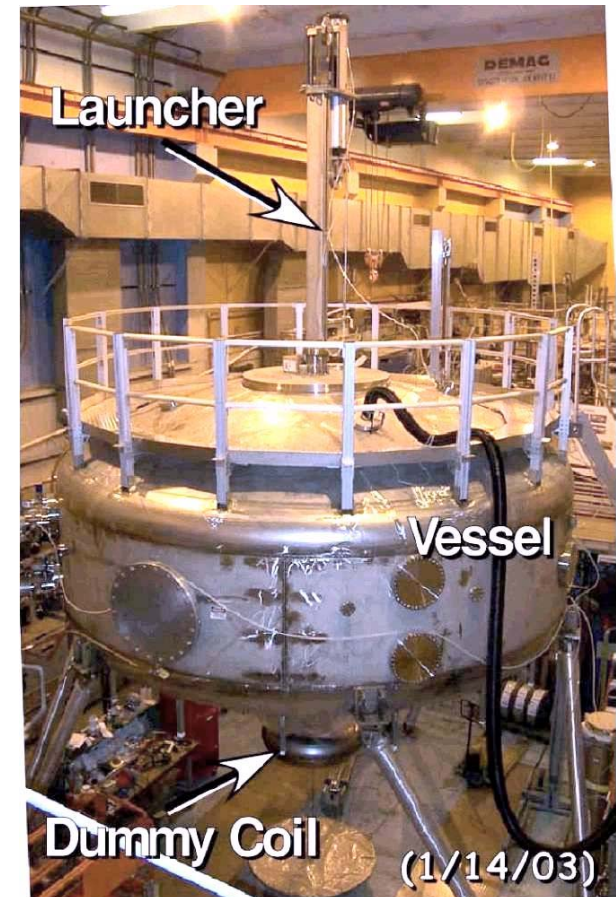
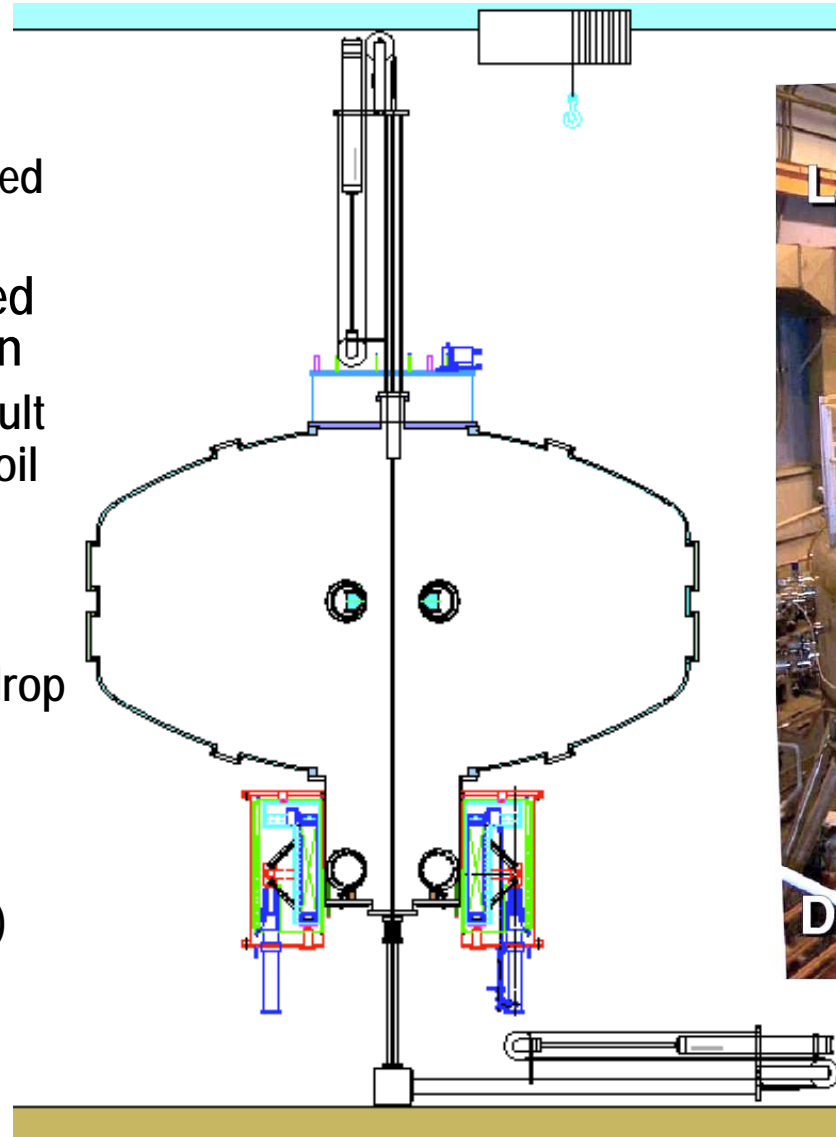

Levitation Control System

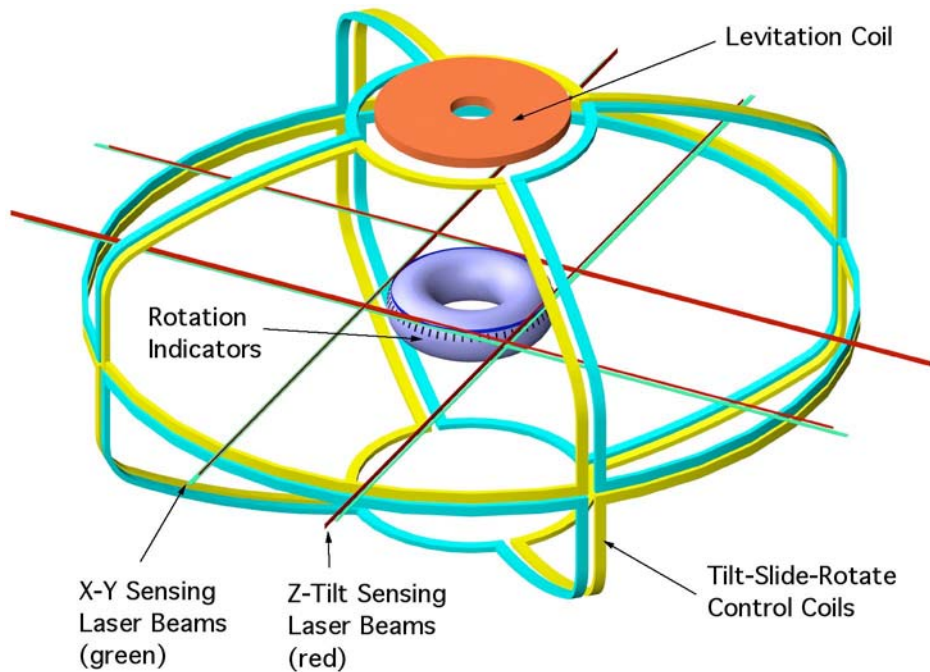

- Levitation from above
 - Requires stabilization of vertical motion by feedback
 - Other motions are stable
- Levitation control system
 - Optical detection system measures position and attitude of floating coil with 10 μm resolution
 - Digital control system

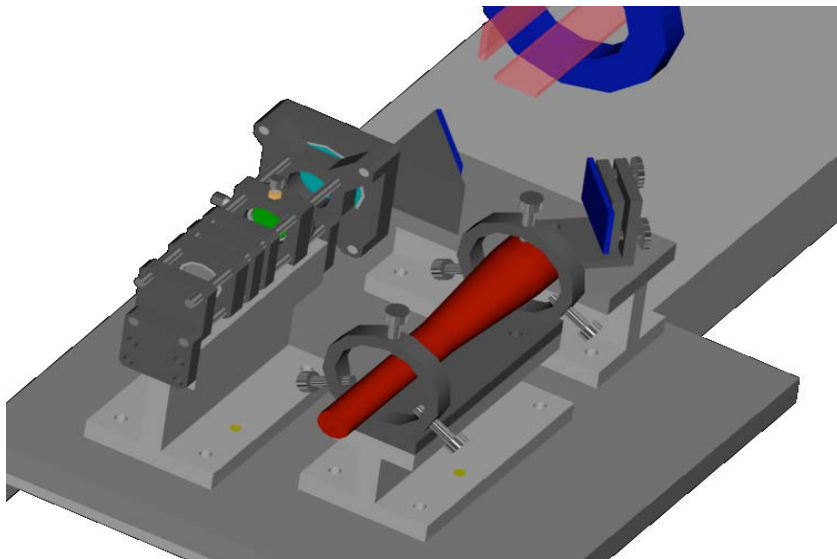

Digital Feedback System

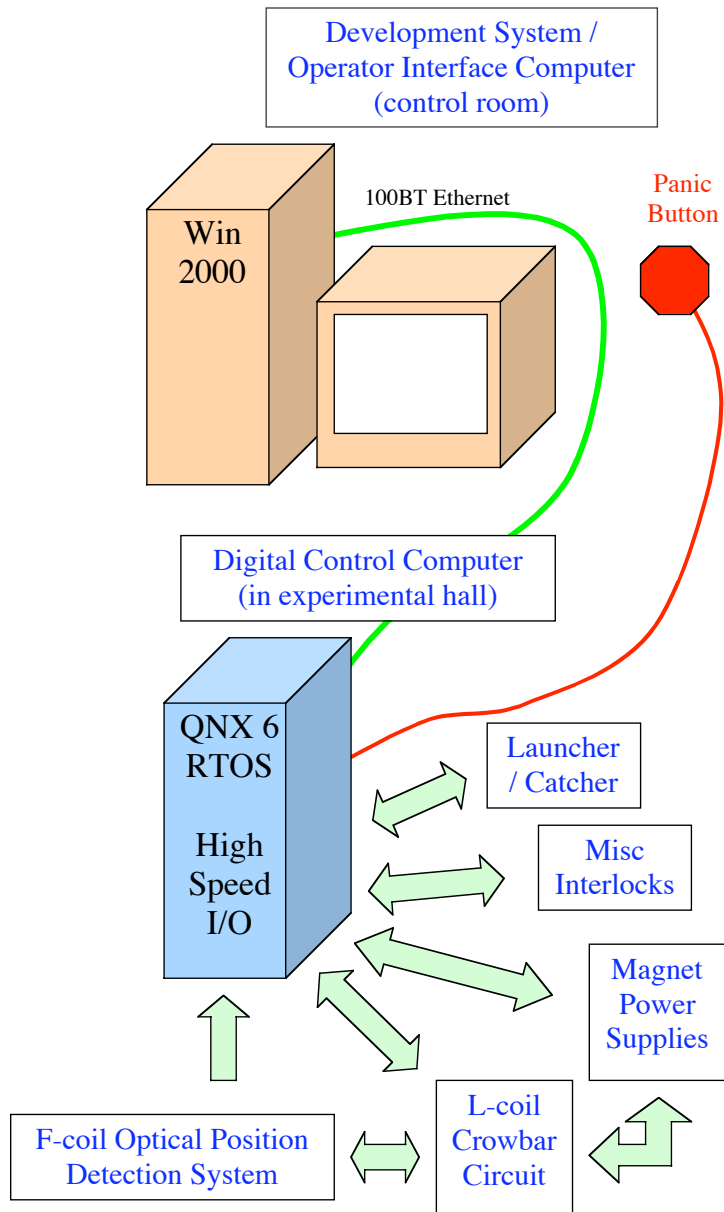

- **Design Requirements**
 - All digital process control
 - Mathworks Matlab/Simulink design tool and visualization software
 - Process control on hard real-time operating system based computer
- **Modular Opal-RT / QNX Neutrino Real-time system implemented**
 - Hardware/Software testing with desktop model - LCX II

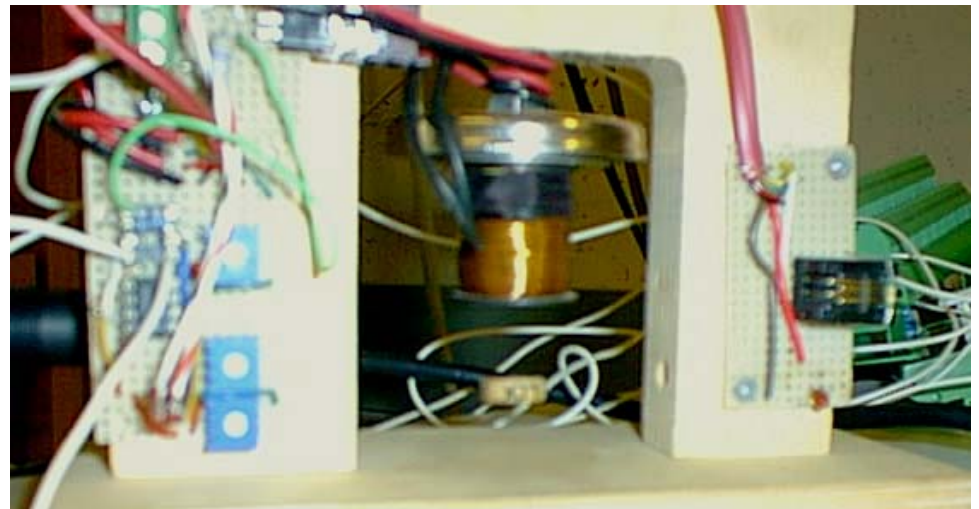

Multi-frequency ECRH on LDX

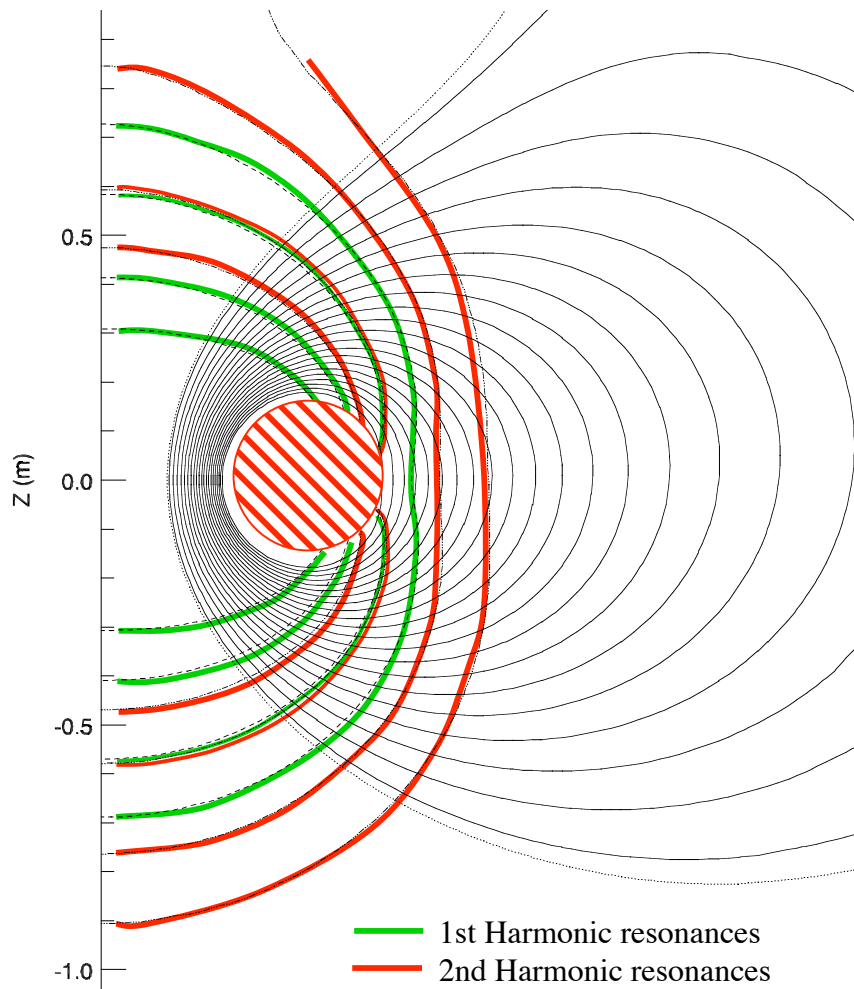

- Multi-frequency electron cyclotron resonant heating
 - Effective way to create high- β hot electron population
 - Tailor multi-frequency heating power to produce ideal (stable) pressure profile with maximum peak β .

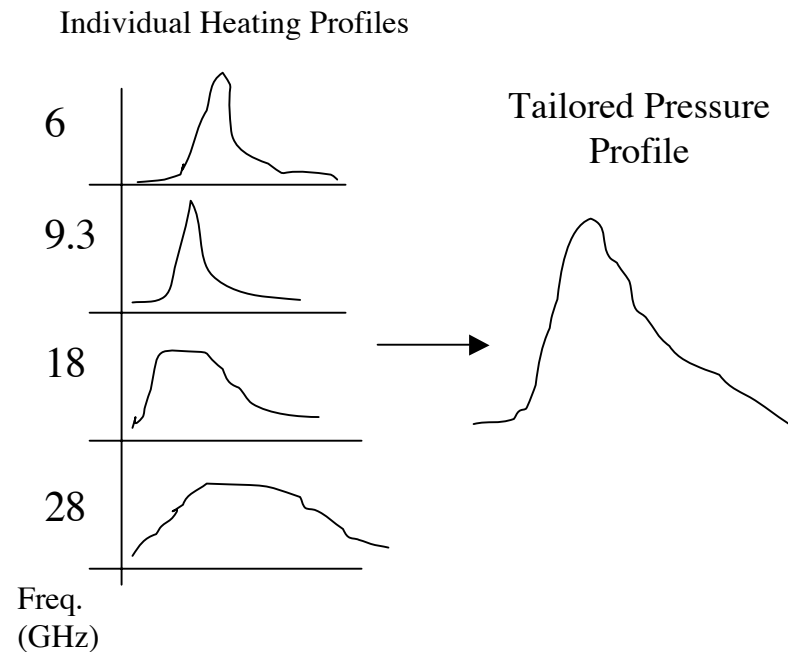

LDX Experimental Goals

- **Investigate high-beta plasmas stabilized by compressibility**
 - Also the stability and dynamics of high-beta, energetic particles in dipolar magnetic fields
 - Examine the coupling between the scrape-off-layer and the confinement and stability of a high-temperature core plasma.
- **Study plasma confinement in magnetic dipoles**
 - Explore relationship between drift-stationary profiles having absolute interchange stability and the elimination of drift-wave turbulence.
 - Explore convective cell formation and control and the role convective cells play in transport in a dipole plasma.
 - The long-time (near steady-state) evolution of high-temperature magnetically-confined plasma.
- **Demonstrate reliable levitation of a persistent superconducting ring using distant control coils.**

LDX Experimental Plan

- **Supported Dipole Hot Electron Plasmas**
 - High- β Hot Electron plasmas with mirror losses
 - ECRH Plasma formation
 - Instabilities and Profile control
- **Levitated Dipole Hot Electron Plasmas**
 - No plasma losses to supports
 - β enhancement
 - Confinement studies
- **Thermal Plasmas**
 - Thermalization of hot electron energy with gas puffs / pellets
 - Convective cell studies
 - Concept Optimization / Evaluation

Initial Plasma Diagnostic Set

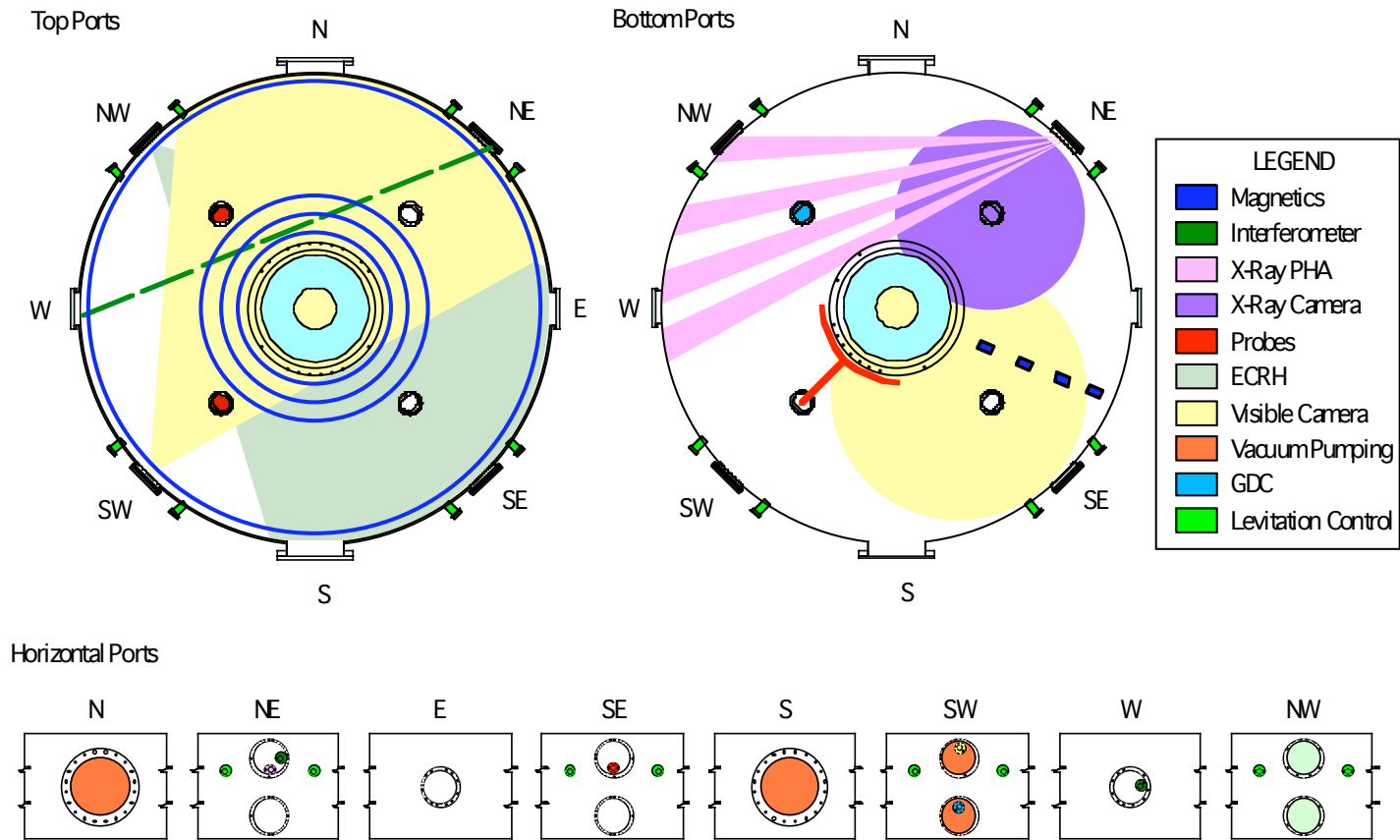

- Magnetics (flux loops, hall probes)
 - Plasma equilibrium shape
 - Mirnov coils for magnetic fluctuations
- Interferometer
 - Density profile and macroscopic density fluctuations
- X-rays diagnostics
 - PHA hot electron energy distribution / profile
 - Hard X-Ray Camera
- D_{α} camera
- Edge probes
 - Edge plasma density and temperature
 - Fluctuations

Initial Supported Hot Electron Plasmas

- Low density, quasi steady-state plasmas formed by multi-frequency ECRH with mirror-like losses from supported dipole
 - Areas of investigation
 - ◆ Plasma formation & density control
 - ◆ Pressure profile control with ECRH
 - ◆ Supercritical profiles & instability
 - ◆ Compressibility Scaling
 - ◆ ECRH and diagnostics development
 - Unique to supported operation
 - ◆ B field scaling
 - ◆ Floating ring potential control

What's new since ICC '03?

- **F-coil**
 - F-coil delivered to MIT October
 - LN2 Cold Test November
 - Internal He leaks identified and repaired Nov-March
 - Final vessel closeout welds March-April
 - LHe Cold Test May 6, 2004
 - Installed in LDX Chamber last week!
- **C-coil**
 - C-coil delivered to MIT September
 - Cryostat vacuum system upgraded Sept-Nov
 - Installed under machine December
 - Installed cryogenic, electrical, and control systems Sept-Jan
 - 400 Amp Test Feb 1, 2004
- **Charging Station**
 - Subsystems fit-up checkout October
 - Vacuum chamber completed and checked November
 - Final installation of internal mechanisms Now!
- **Plasma Systems**
 - Install and Test Gas Puffing system February
 - Install and Test Glow Discharge Cleaning system March-April

Short Term LDX Schedule

- **Final installation**
 - Charging station mechanical checkout
 - Last leg of cryogenics plumbing into Charging Station
 - Installation of vacuum cryopumps
 - Hookup of ECRH systems
 - Final diagnostics installation
- **LDX Magnet Systems Integrated Test**
 - First use of C-coil to charge F-coil inductively
 - All cryogenic, control, and magnet systems to be in operation
- **Pump down**
 - Seal F-coil and LDX Chamber
 - Pump down and Glow Discharge Clean
- **First Dipole Plasma**
 - Supported operation begins...

LDX Magnet Systems Integrated Test

- **Goals of Integrated Test**
 - Calibrate C-coil Quench Detection System
 - Demonstrate charging of F-coil
 - Determine operational time for experiment
- **Last major milestone before first plasma...**
- **Method**
 - Several ramps at moderate current with F-coil in warm and cold state to calibrate C-coil quench detection system.
 - ◆ Eddy currents can look like a quench if not calibrated properly.
 - Charge the F-coil to various (low) currents and let warm until magnet quench.
 - ◆ T_c determined at several magnetic fields and current densities.
 - ◆ Using these points and using scaling laws determined from modeling and previous conductor tests, we will determine final full current quench temperature (and thus total operation time.)
 - Thermal Modeling of F-coil thermal
 - ◆ Comparison of data obtained with model of coil should allow us to differentiate between various heat leaks

Conclusions

- LDX is the first experiment to investigate plasmas stabilized by compressibility with near-classical confinement
 - Capable of directly testing effects of compressibility, pressure profile control and axisymmetry on plasma stability and confinement
 - Relevant to both space and laboratory fusion plasma physics
- Initial diagnostic set and experimental plan to focus on stability of high- β hot electron plasmas in supported and levitated operation
- LDX is a “world class” superconducting fusion experiment with sophisticated magnet technology
 - Three unique superconducting magnet systems are received at MIT and nearly completed
- Check www.psfc.mit.edu/ldx/ for updates on progress