

Status of LDX Fabrication

M. E. Mael, D. T. Garnier, A. Hansen, T. Sunn Pedersen, E. Ortiz, *Columbia University*
 J. Kesner, C. M. Jones, I. Karim, J. Minervini, P. Michael, A. Radovinsky, J. H. Schultz, B. A. Smith,
 A. Zhukovsky, *MIT Plasma Science and Fusion Center*

Abstract

The Levitated Dipole Experiment (LDX) will be the first experiment able to study high-beta plasma confined by a magnetic dipole with near classical energy confinement. LDX consists of three superconducting magnets and illustrates the role of innovative magnetic technology that makes possible explorations of entirely new confinement concepts. In this poster, we describe the LDX machine design and detail the fabrication status of the superconducting floating-coil, charging-coil, and levitation-coil. In addition, we summarize our plan to test the operation of the superconducting magnets and our procedure to cool, to inductively charge, and to levitate the 1.3 MA floating coil.

The LDX Team is a partnership of plasma scientists and magnet technology experts. In order to achieve our scientific objectives, LDX required innovative engineering and design. The LDX design was motivated by several factors: (1) a sufficiently large size to allow for large magnetic flux expansion, (2) the highest possible field consistent with low-weight which allowed use of ECRH to start-up high-beta plasma equilibria ($\beta \sim 30\%$) and reduced effects from field-errors and from levitation fields, (3) the experience from previous levitron and spherator experiments, and (4) desire for simple cryogenics. The resulting design consisted of three innovative magnets: (1) a high-field persistent Nb^3Sn floating coil with low mass, small size, a light-weight cryostat with distributed supports having low-thermal conductivity, and relatively easy-to-operate cryogenics, (2) a large, inductive charging system designed for thousands of high-field cycling through daily charging and discharging, and (3) fusion's first high-temperature superconducting magnet providing a distant levitation coil coupled to a laser-based stabilization system.

All three coil systems will be completed during the next few months. The floating Coil (714 turns, Nb^3Sn , 5T, 1.3 MA-turns) has been completed and tested at full current. Ability Engineering (South Holland, IL) is completing final assembly of the outer cryostat. The charging coil (8000 turns, NbTi, 5T, 4.2 MA-turns) has been wound by SINTEZ/Science Technology Center (St. Petersburg, Russia), and manufacturing of its cryostat has begun. Finally, the HT_cSC levitation Coil (1310 turns, steel-reinforced Bi-2223, 0.275 MA-turns) is being built by Everson Electric (Allentown, PA). Winding of this coil should begin by this meeting.

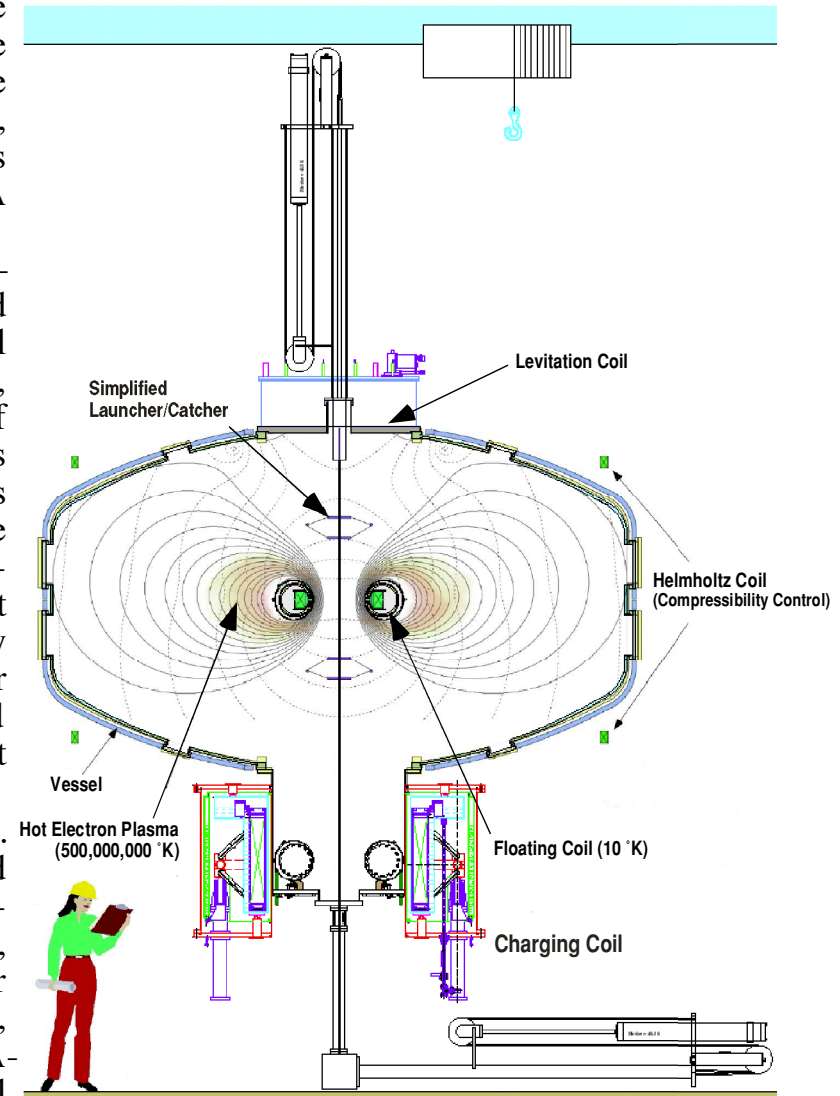

The Dipole Concept Originated by Seeking to Capture in the Laboratory the Physics of Nature's High-Beta Plasma

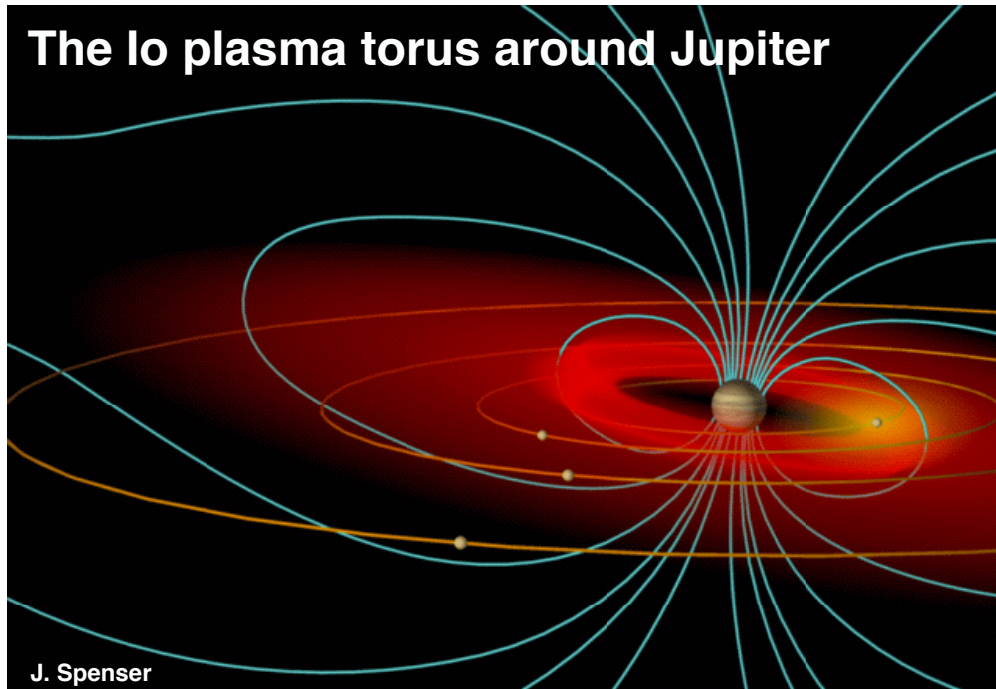

- High-beta confinement occurs naturally in magnetospheres
- $\beta \sim 2$ in Jupiter
- Most common “confining magnetic field” in the universe
- Plasma compressibility allows finite pressure gradients—stabilizing both MHD and drift instabilities.
- When field errors are small, “classical confinement” may be possible.

The LDX Team is a Partnership of Plasma Scientists and Magnet Technology Experts

LDX required innovative engineering and design:

- High-field persistent Nb₃Sn coil with low mass and small size
- Innovative, light-weight cryostat with distributed supports having low-thermal conductivity
- Safe, relatively easy-to-operate cryogenics
- Large, inductive charging system designed for thousands of high-field cycling during daily charging and discharging
- Fusion's first high-temperature superconducting magnet
- Levitation and stabilization system with distant, upper levitation coil

Factors in the LDX Design

- Overall size sufficiently large to allow for large magnetic flux expansion
- Highest possible field consistent with low-weight:
 - Use ECRH start-up to create high-beta plasma ($\beta \sim 30\%$)
 - Reduce effects from field-errors and levitation fields
- Use experience from previous levitron and spherator experiments
- Optimize cryogenics to simplify maintenance and operations

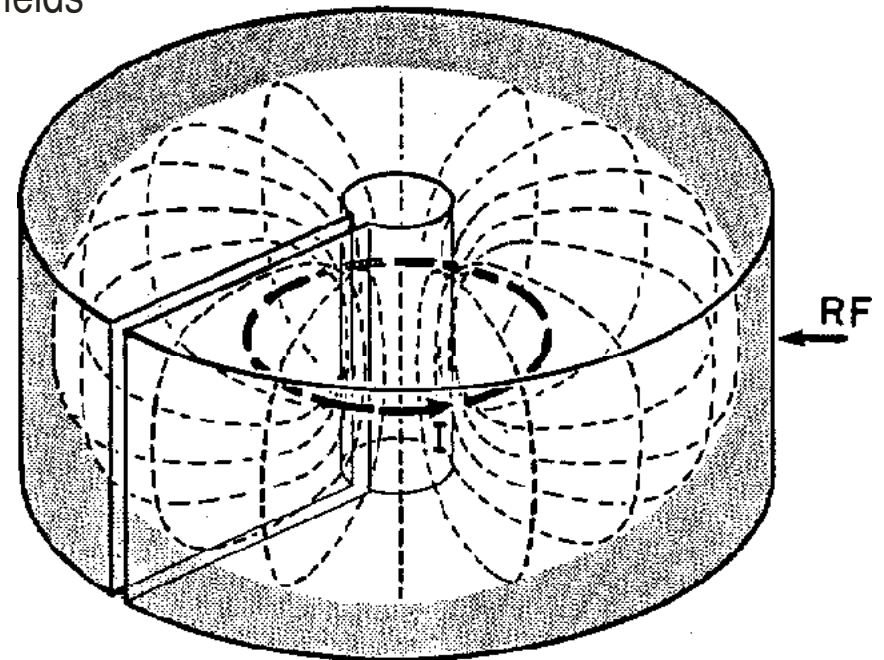

First Proposed: 1988

The Levitated Dipole Experiment

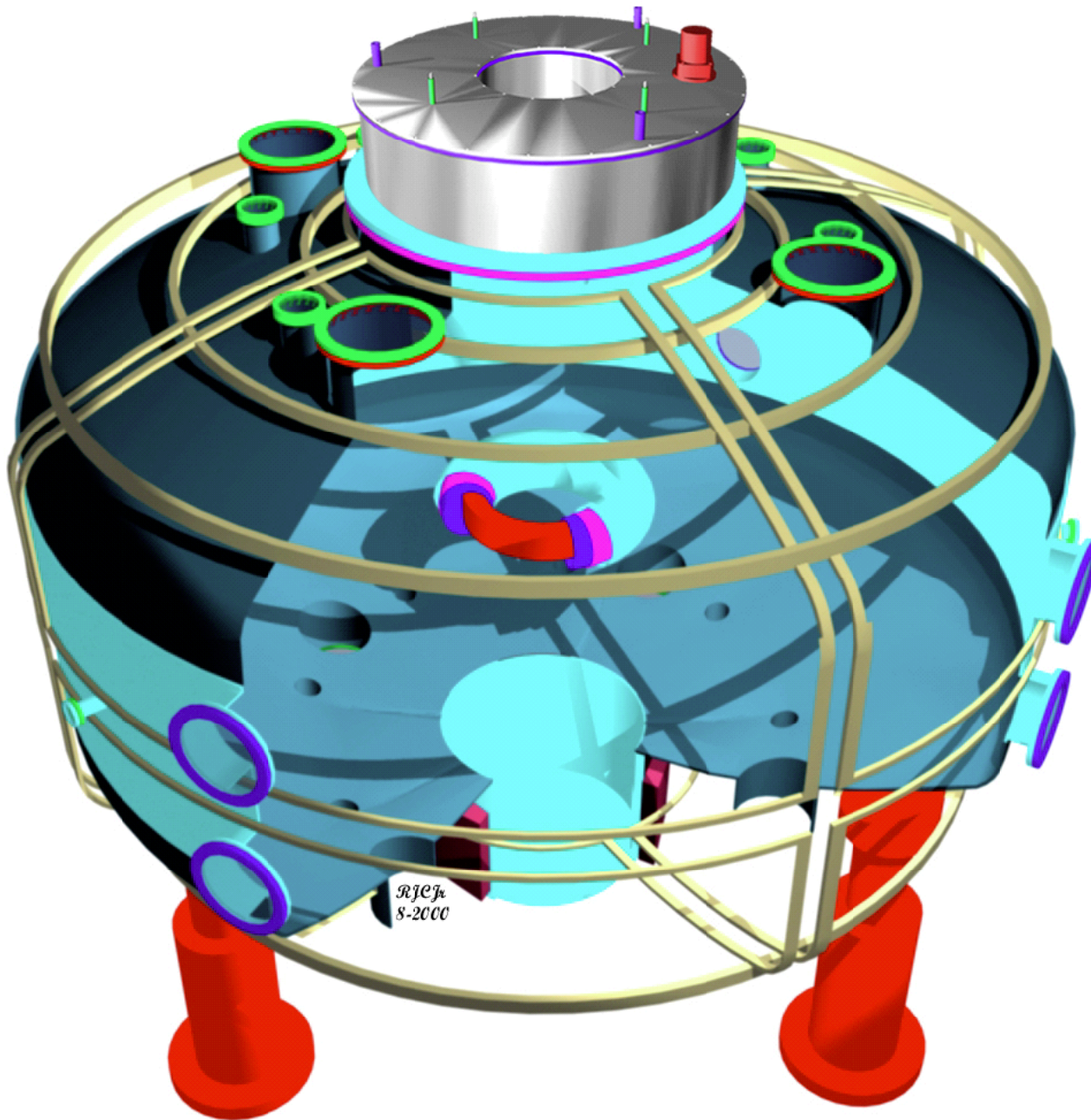

The goal of the LDX experimental program is to investigate the possibility of steady-state, high beta dipole confinement with near classical energy confinement

...for the first time!

LDX Superconducting Coil Manufacturing Status:

Floating Coil (714 turns, Nb₃Sn, 5T, 1.3 MA turns)

Ability Engineering (South Holland, IL)

- Floating coil has been completed and tested at full current and encased into high-pressure He vessel
- Final assembly of outer cryostat is underway

Charging Coil (8000 turns, NbTi, 5T, 4.2 MA turns)

SINTEZ/Science Technology Center (St. Petersburg, Russia)

- Completed R&D tests of conductor, insulation, electromechanical properties
- Coil winding completed. VPI scheduled this week.
- Manufacturing of cryostat scheduled

Levitation Coil (1310 turns, High Strength Bi-2223, 0.275 MA turns)

Everson Electric (Allentown, PA)

- Conductor supplied by ASC
- Joint and winding plan complete
- Winding to begin next month

LDX Research Plan

Complete fabrication of the superconducting magnets

- The LDX project required the construction of an entirely new experimental facility that includes three superconducting magnets.

Today, our primary focus is to oversee completion of these magnet systems.

Establish safe and reliable operation

- Initial operation will include experiments with a supported dipole.
- Our launching apparatus (PPPL, CU, MIT) allows levitation while protecting the floating coil from loss of control or quench.

Physics studies include (1) understanding pressure profile effects on MHD stability, (2) electrostatic & magnetic stability, (3) transport and scaling.

Floating Coil: Final Assembly

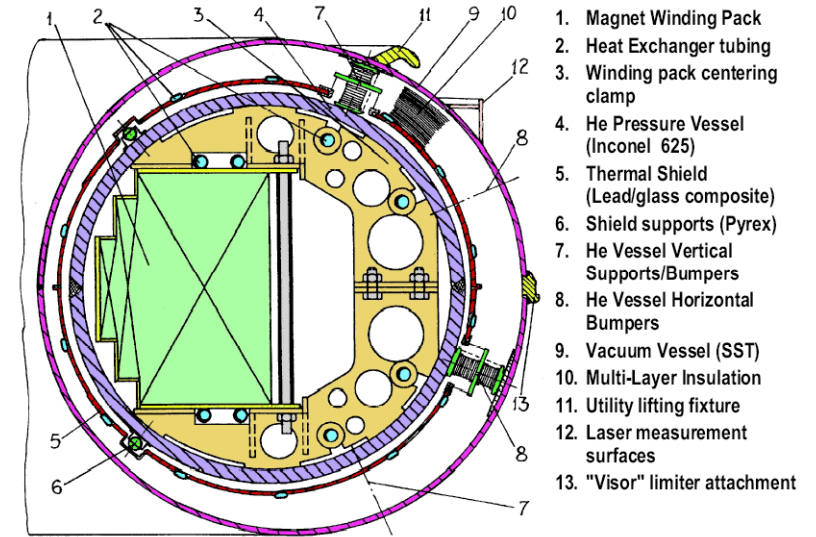

Floating Coil Test Successful (July 2000)

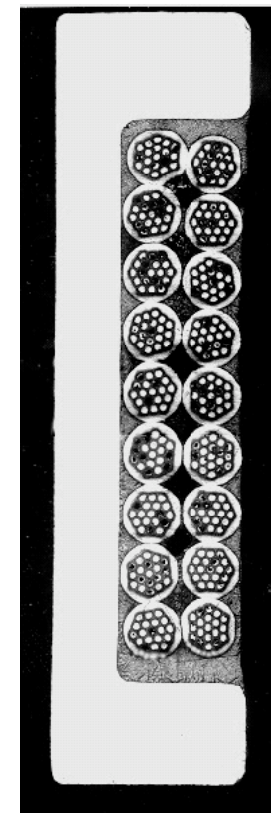
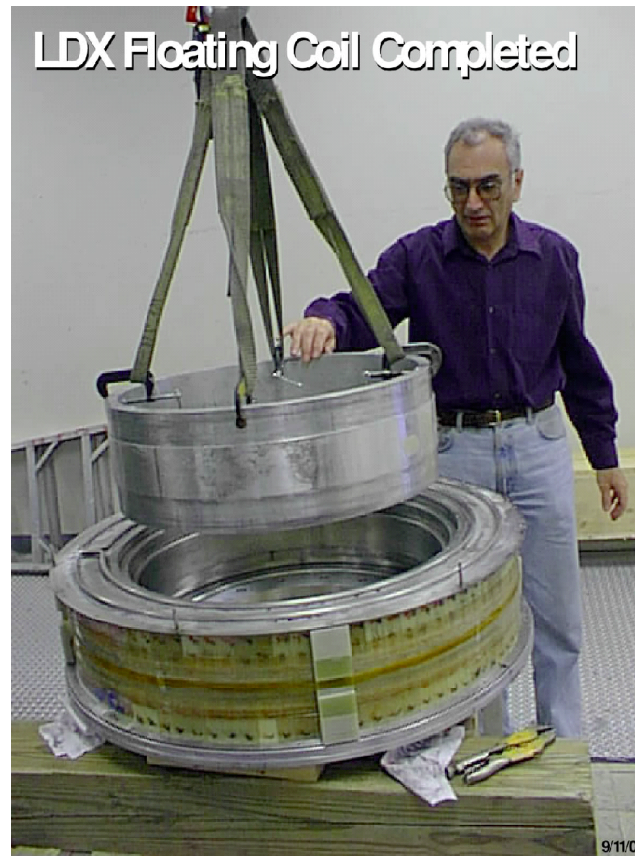

Floating Coil Cryostat Assembly

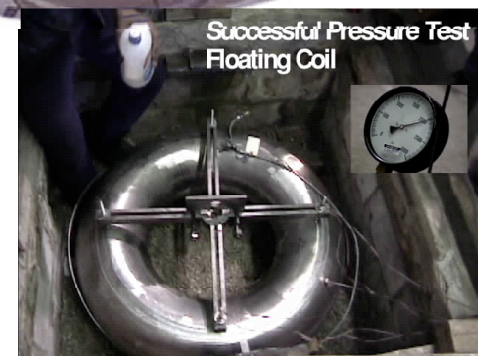
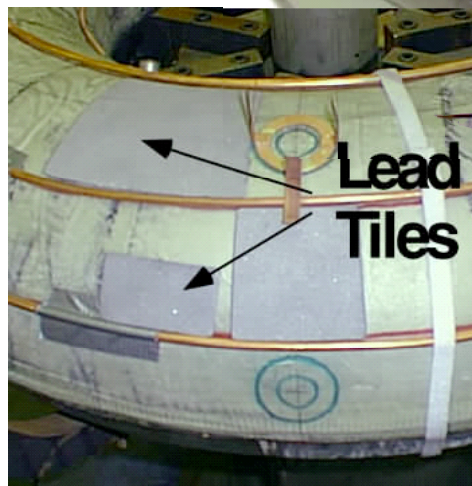
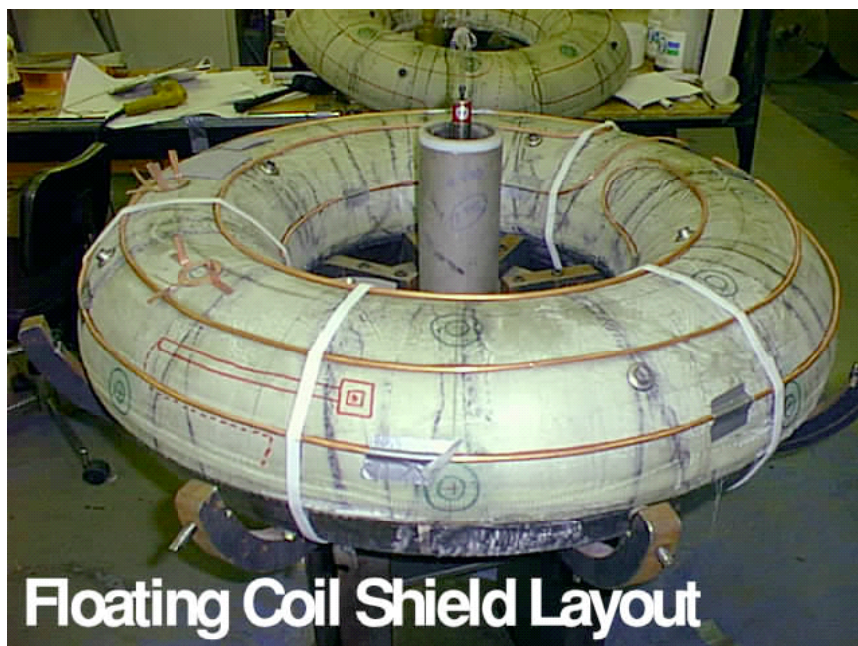
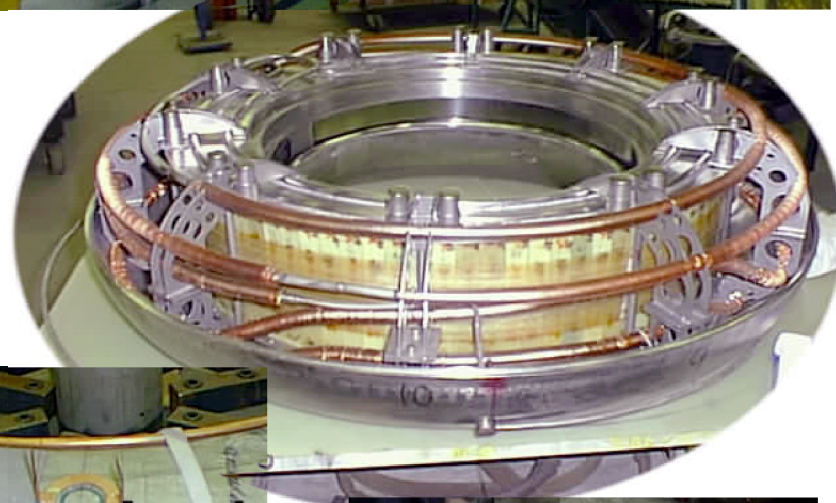
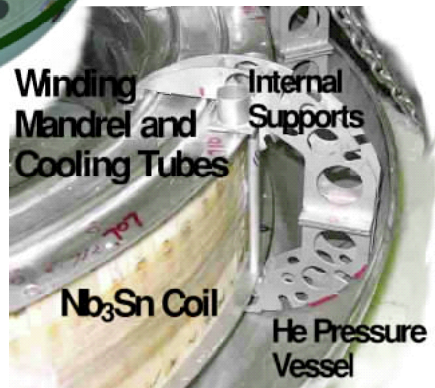
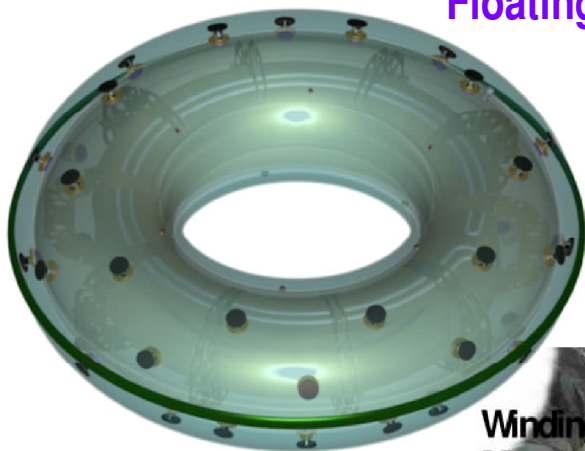

Charging Coil: Winding Complete

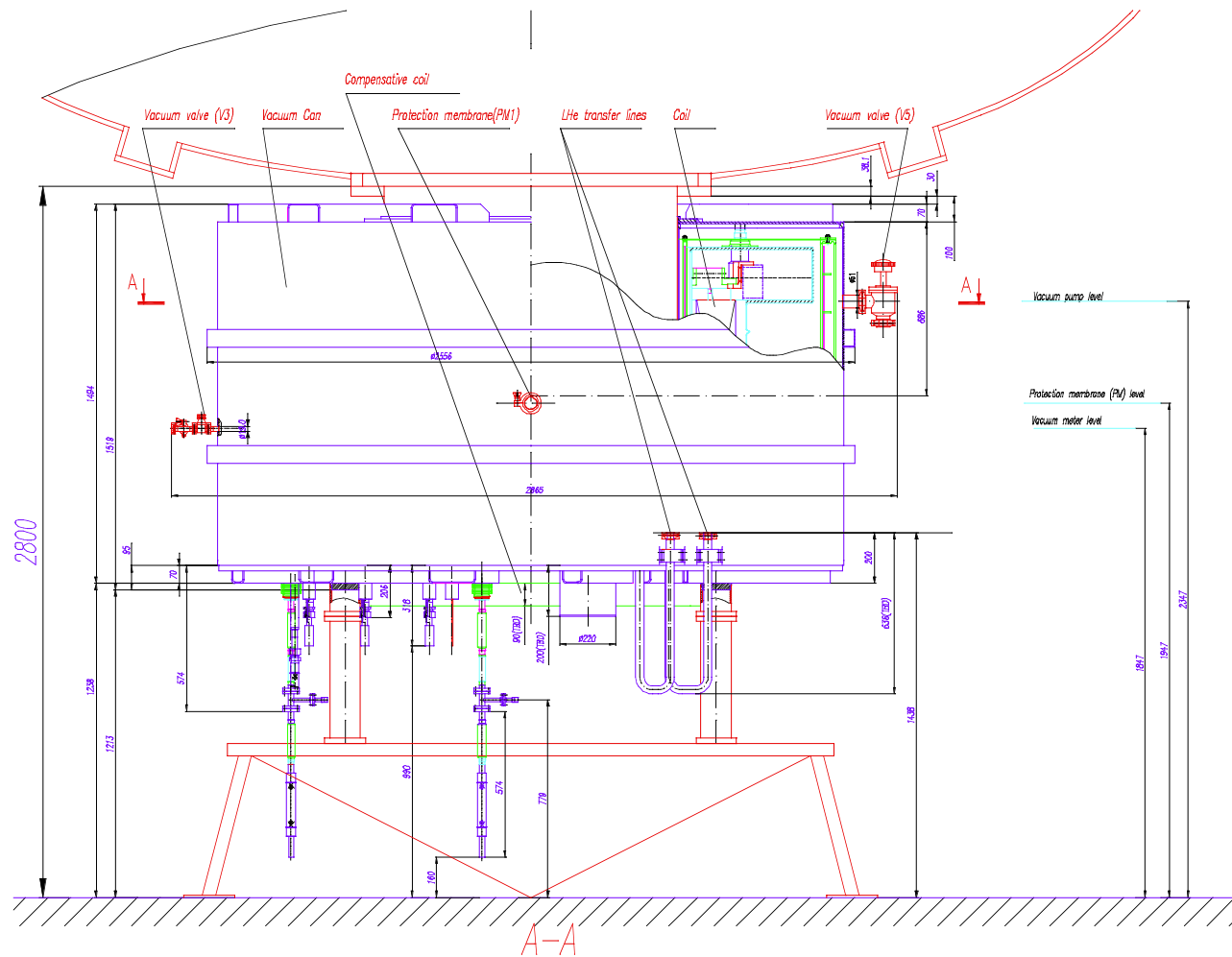

SINTEZ/Science Technology Center
St. Petersburg, Russia



Winding
Tool Layout

Thorough Technology Development and Test Prior to Coil Winding...



R&D Test & Validation Winding



Applying Glass Ground
Insulation



Three Layers Completed

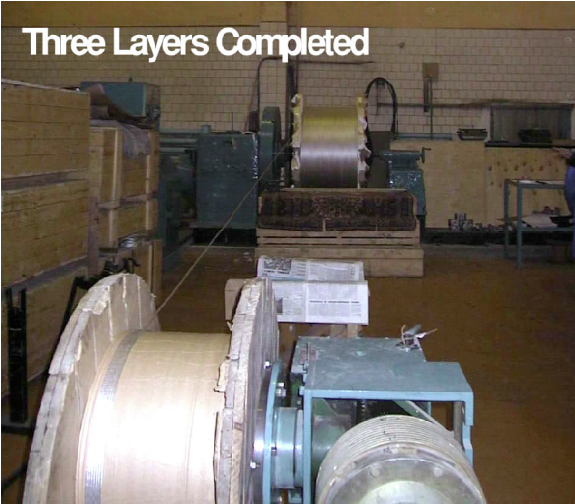

Nov01: Winding in progress

Jan02: Completed; Ready for VPI



Levitation Coil: Fusion's First HT_c Magnet

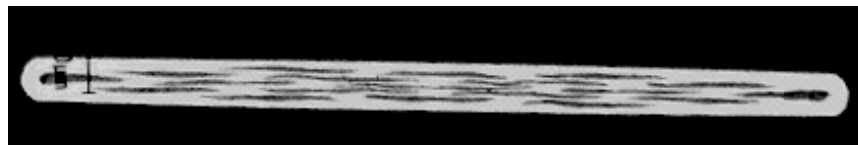

ASC Bi-2223 "Narrow" Tape

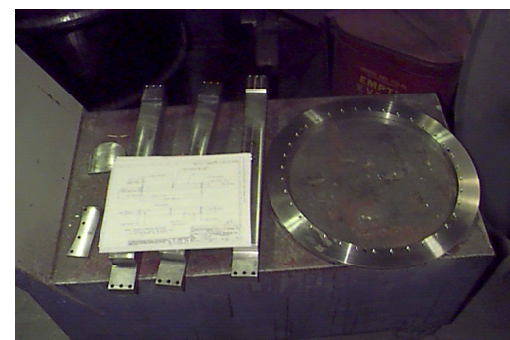
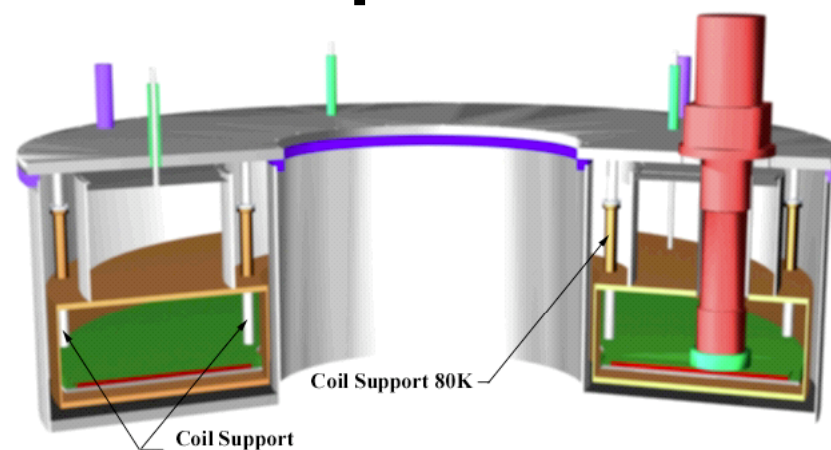
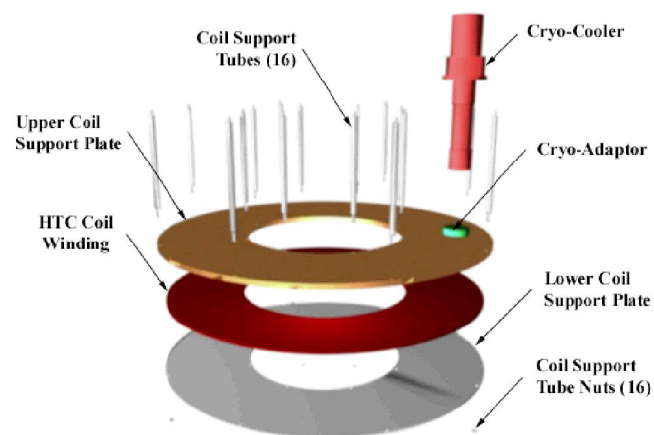

ECRH, Control, Basic Diagnostics On Schedule

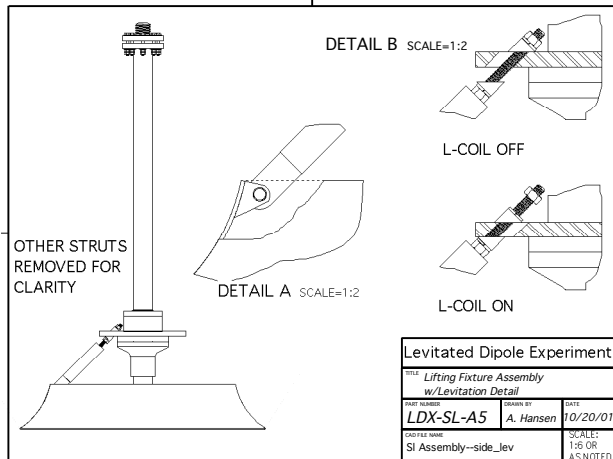

6 GHz



10.5 GHz

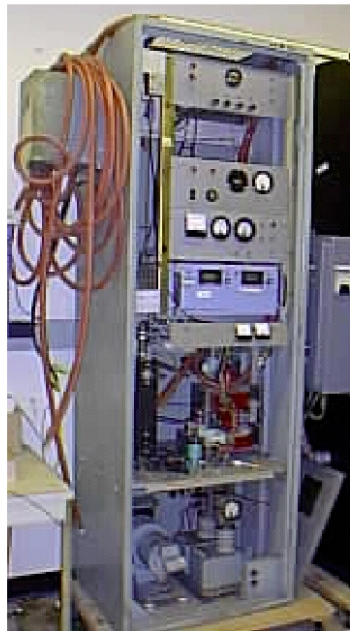

LDX Status Summary

- The LDX project required construction of an entirely new experimental facility that includes three new superconducting magnets.

Today, our primary focus is to oversee completion of these magnet systems.

- We expect all components necessary to begin experiments to be delivered to MIT before the end of the summer.

After initial systems tests, physics experiments will begin this year.

- LDX has involved innovative technology and complex systems integration that has required more effort and time than initially expected.

However, LDX has advanced magnet technology and is succeeding in the construction of a safe and reliable first-of-a-kind and world-class experimental facility!